

4

3

2

1

F

F

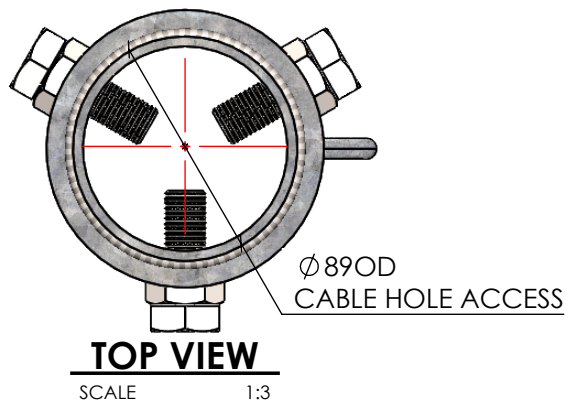

E

E

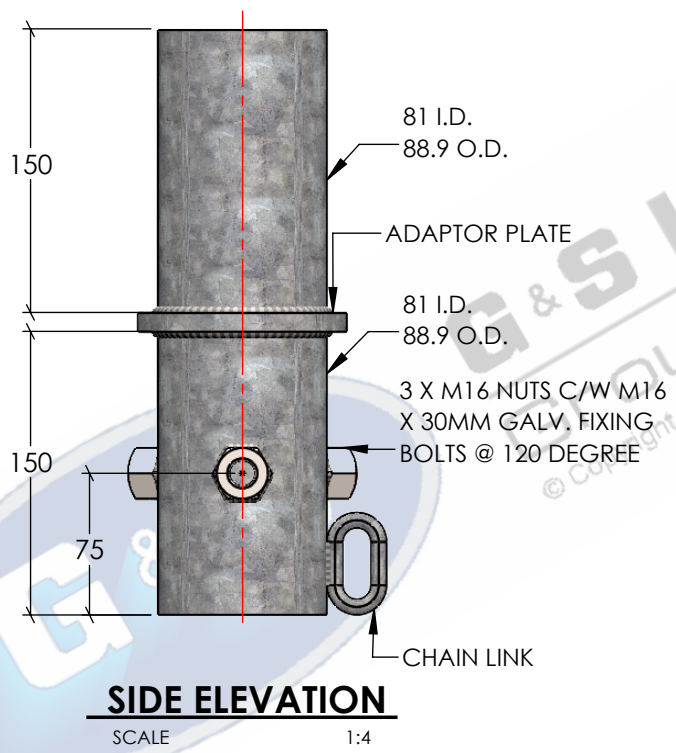

D

D

C

C

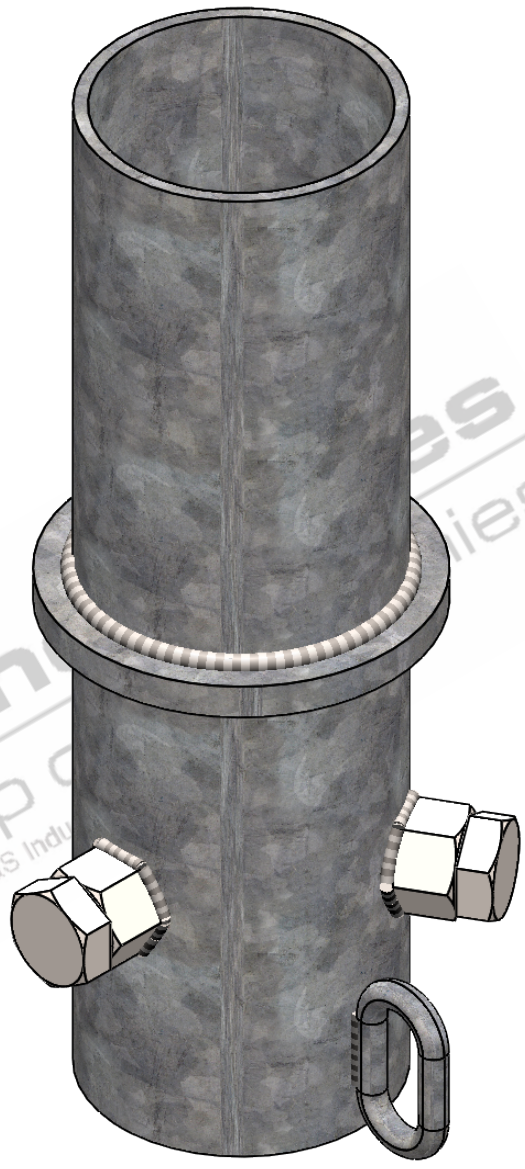

B

B

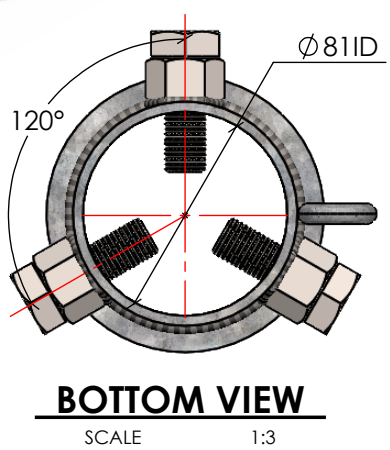

***80NB/90OD TO 80NB/90OD**

- STANDARDS
ALL PRODUCTS TO CONFORM TO THE FOLLOWING AUSTRALIAN STANDARDS
- * AS 1554(set) Structural steel welding set.
 - * AS 2159: Piling - Design & Installation.
 - * AS 2870: Residential slab footings - Construction.
 - * AS 3600: Concrete structures.
 - * AS 3678: Structural steel - Hot rolled plates, floorplates and slabs.
 - * AS 4680: Hot dip galvanized (Zinc) Coatings on fabricated ferrous articles.
 - * AS/NZS 4671: Steel reinforcing materials.
 - * AS/NZS 4676: Structural design requirements for utility services poles.

A

A



G&S Industries
Group of Companies
97 GUTHRIE STREET,
OSBORNE PARK W.A. 6017
PH : +6108 9446 8044
EMAIL: sales@gsindustries.com.au
WEB: www.gsindustries.com.au

PROPRIETARY AND CONFIDENTIAL
THE INFORMATION CONTAINED IN THIS DRAWING IS THE SOLE PROPERTY OF G&S INDUSTRIES. ANY REPRODUCTION IN PART OR AS A WHOLE WITHOUT THE WRITTEN PERMISSION OF G&S INDUSTRIES IS PROHIBITED.

SCALE: AS SHOWN

PRODUCT FINISH: H.D.G (HOT DIPPED GALVANIZED) PRODUCT WEIGHT: 3.4kg.

CUSTOMER APPROVAL:

CUSTOMER NAME / PROJECT:

	NAME	DATE
DRAWN	N.C. A.	04.06.2020
CHECKED	RG	04.06.2020
REVISED	N.C. A.	30.06.2020
COPYRIGHT		
THIS DOCUMENT IS PRODUCED BY G&S INDUSTRIES MUST NOT BE COPIED, TRACED, REPRODUCED, OR LENT WITHOUT WRITTEN CONSENT		

PART NUMBER :	SA80NB/90OD	
TITLE :	SPIGOT ADAPTOR 80NB/90OD TO 80NB/90OD	
SIZE	DWG. NO.	REV.
A4	ZLRG713A5	0
SHEET 1 OF 1		

4

3

2

1