

TOP VIEW

SCALE 1:12

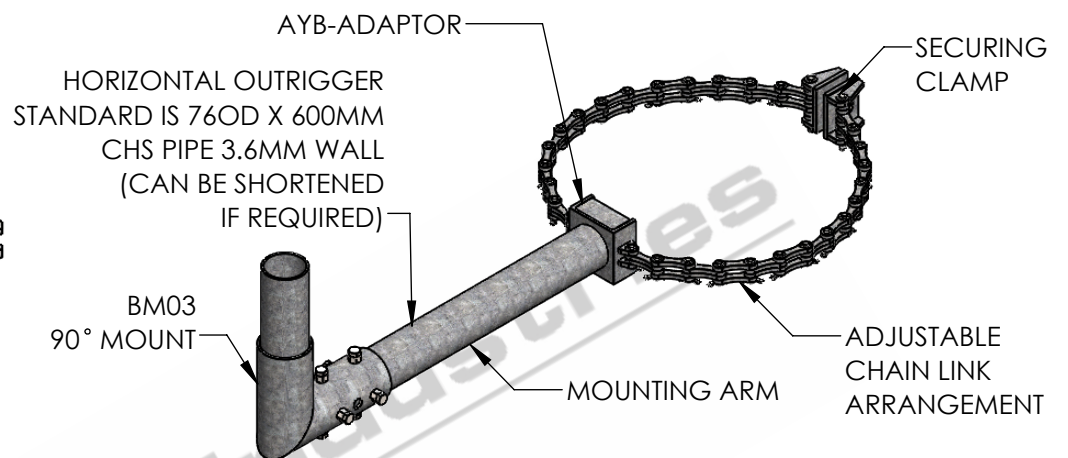

ISOMETRIC VIEW

SCALE 1:12

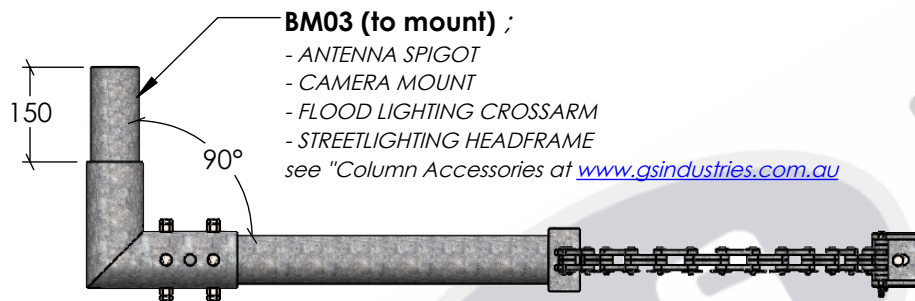

SIDE VIEW

SCALE 1:12

BM03 (to mount) ;
 - ANTENNA SPIGOT
 - CAMERA MOUNT
 - FLOOD LIGHTING CROSSARM
 - STREETLIGHTING HEADFRAME
 see "Column Accessories at www.gsindustries.com.au

BM03 TO SUIT :

SELECT FROM ACCESSORIES AT www.gsindustries.com.au

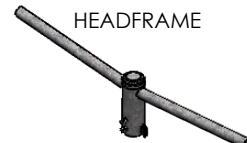
FLOOD LIGHTING CROSSARM 	STREET LIGHTING HEADFRAME 
ANTENNA SPIGOT 	CAMERA ADAPTOR 

	A IF < 600MM	B (IF KNOWN)	C QTY. OF ARMS (IF MORE THAN 1)
DIMENSION			

STANDARDS

- ALL PRODUCTS TO CONFORM TO THE FOLLOWING AUSTRALIAN STANDARDS.
 * AS 1170.2 Structural design actions - Wind actions.
 * AS 1554(set) Structural steel welding set.
 * AS 2159: Piling - Design & Installation.
 * AS 2870: Residential slab footings - Construction.
 * AS 3600: Concrete structures.
 * AS 3678: Structural steel - Hot rolled plates, floorplates and slabs.
 * AS 4680: Hot dip galvanized (Zinc) Coatings on fabricated ferrous articles.
 * AS/NZS 4671: Steel reinforcing materials.
 * AS/NZS 4676: Structural design requirements for utility services poles.
 * AS/NZS 4600: Cold formed steel structures.



G & S Industries
 97 GUTHRIE STREET,
 OSBORNE PARK W.A. 6017
 PH : +6108 9446 8044
 EMAIL: sales@gsindustries.com.au
 WEB: www.gsindustries.com.au

PROPRIETARY AND CONFIDENTIAL		NAME	DATE	PART NUMBER : PCB-CL-MULTI	
THE INFORMATION CONTAINED IN THIS DRAWING IS THE SOLE PROPERTY OF G&S INDUSTRIES . ANY REPRODUCTION IN PART OR AS A WHOLE WITHOUT THE WRITTEN PERMISSION OF G&S INDUSTRIES IS PROHIBITED.		DRAWN	N. A.	14.10.2022	TITLE : ADJUSTABLE POLE CLAMP BRACKET - MULTI LIGHTING / CCTV / COMMS.
SCALE: AS SHOWN	PRODUCT WEIGHT: 13.3kg. BM03 NOT INCLUDED	CHECKED	S. G.	14.10.2022	
PRODUCT FINISH: HOT DIPPED GALVANIZED	CUSTOMER APPROVAL :	APPROVED	R. G.	14.10.2022	
CUSTOMER NAME / PROJECT :		COPYRIGHT		SIZE DWG. NO.	REV.
		THIS DOCUMENT IS PRODUCED BY G&S INDUSTRIES MUST NOT BE COPIED, TRACED, REPRODUCED, OR LENT WITHOUT WRITTEN CONSENT		A4	ZLRG3245A
				SHEET 1 OF 2	

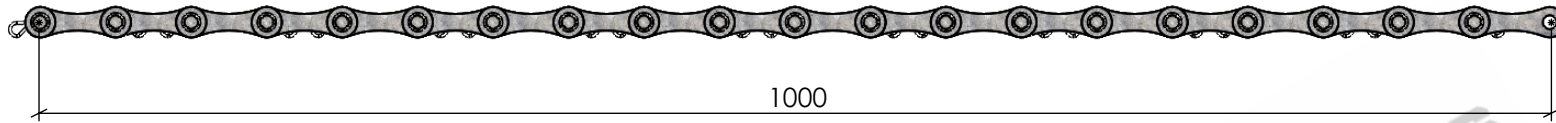

TOP VIEW
SCALE 1:5

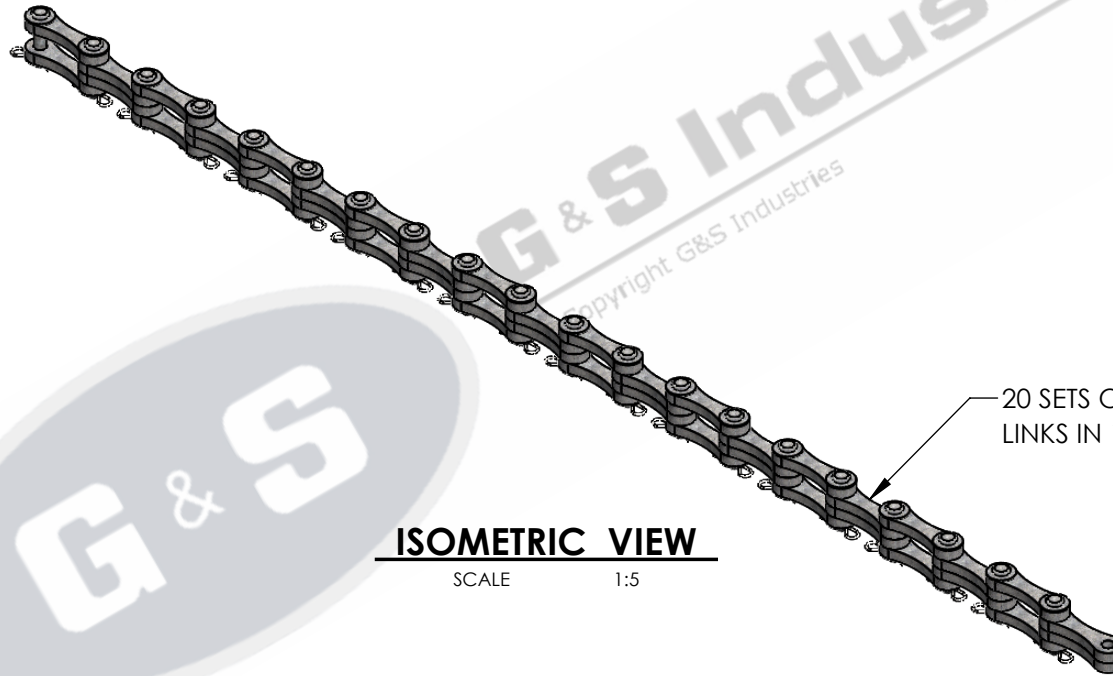

ISOMETRIC VIEW
SCALE 1:5

20 SETS OF DOGBONE CHAIN LINKS IN 1MTR. LENGHT

STANDARDS

- ALL PRODUCTS TO CONFORM TO THE FOLLOWING AUSTRALIAN STANDARDS.
- * AS 1170.2 Structural design actions - Wind actions.
 - * AS 1554(set) Structural steel welding set.
 - * AS 2159: Piling - Design & Installation.
 - * AS 2870: Residential slab footings - Construction.
 - * AS 3600: Concrete structures.
 - * AS 3678: Structural steel - Hot rolled plates, floorplates and slabs.
 - * AS 4680: Hot dip galvanized (Zinc) Coatings on fabricated ferrous articles.
 - * AS/NZS 4671: Steel reinforcing materials.
 - * AS/NZS 4676: Structural design requirements for utility services poles.
 - * AS/NZS 4600: Cold formed steel structures.

G & S Industries
97 GUTHRIE STREET,
OSBORNE PARK W.A. 6017
PH : +6108 9446 8044
EMAIL: sales@gsindustries.com.au
WEB: www.gsindustries.com.au

PROPRIETARY AND CONFIDENTIAL	
THE INFORMATION CONTAINED IN THIS DRAWING IS THE SOLE PROPERTY OF G&S INDUSTRIES . ANY REPRODUCTION IN PART OR AS A WHOLE WITHOUT THE WRITTEN PERMISSION OF G&S INDUSTRIES IS PROHIBITED.	
SCALE: AS SHOWN	PRODUCT WEIGHT: 3kg.
PRODUCT FINISH: HOT DIPPED GALVANIZED	
CUSTOMER APPROVAL :	
CUSTOMER NAME / PROJECT :	

	NAME	DATE
DRAWN	N. A.	14.10.2022
CHECKED	S. G.	14.10.2022
APPROVED	R. G.	14.10.2022
COPYRIGHT		
THIS DOCUMENT IS PRODUCED BY G&S INDUSTRIES MUST NOT BE COPIED, TRACED, REPRODUCED, OR LENT WITHOUT WRITTEN CONSENT		

PART NUMBER :		PCB-CL-MULTI-EXTENSION CHAIN
TITLE :		EXTENSION CHAIN SUIT PCB-CB-MULTI LINK
SIZE	DWG. NO.	REV.
A4	ZLRG3245B	0
SHEET 2 OF 2		