

4

3

2

1

F

F

E

E

D

D

C

C

B

B

A

A

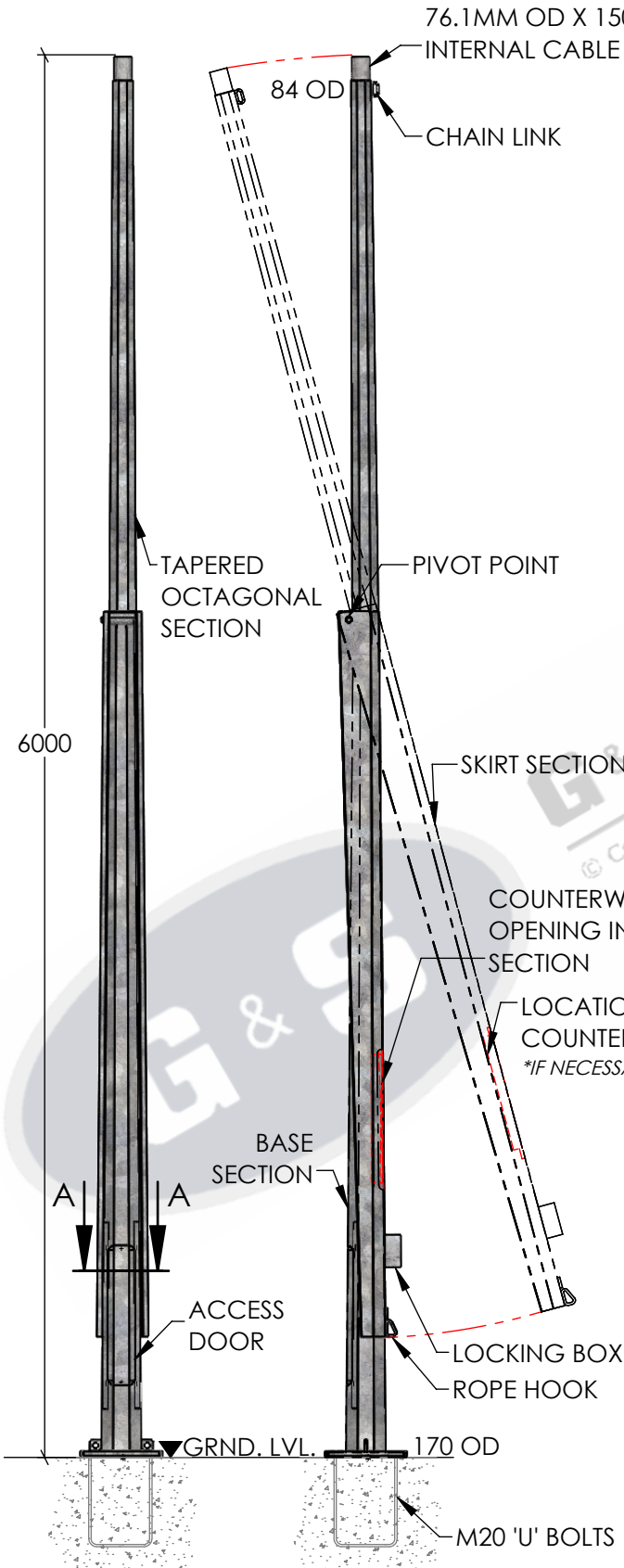

**FRONT & SIDE ELEVATION**

SCALE 1:20

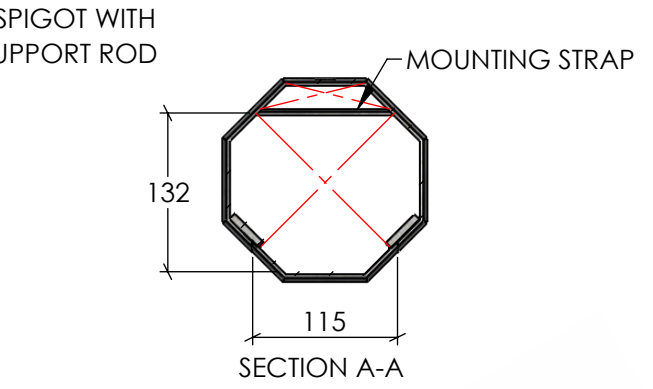

**ACCESS DOOR CLEARANCE DETAILS**

SCALE 1:8

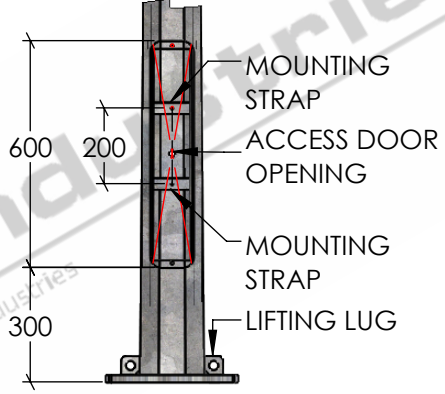

**ELEVATION ON DOOR**

SCALE 1:20

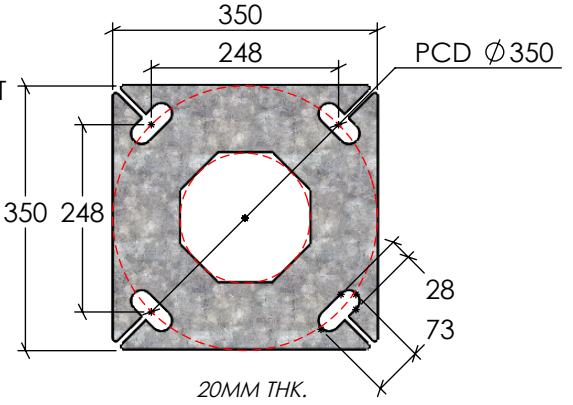

**BASEPLATE DETAILS**

SCALE 1:10

**STANDARDS**

- ALL PRODUCTS TO CONFORM TO THE FOLLOWING AUSTRALIAN STANDARDS.
- \* AS 1170.2 Structural design actions - Wind actions.
  - \* AS 1554(set) Structural steel welding set.
  - \* AS 2159: Piling - Design & Installation.
  - \* AS 2870: Residential slab footings - Construction.
  - \* AS 3600: Concrete structures.
  - \* AS 3678: Structural steel - Hot rolled plates, floorplates and slabs.
  - \* AS 4680: Hot dip galvanized (Zinc) Coatings on fabricated ferrous articles.
  - \* AS/NZS 4671: Steel reinforcing materials.
  - \* AS/NZS 4600: Cold formed steel structures.

**G & S Industries**  
 97 GUTHRIE STREET,  
 OSBORNE PARK W.A. 6017  
 PH : +6108 9446 8044  
 EMAIL: sales@gsindustries.com.au  
 WEB: www.gsindustries.com.au

<b>PROPRIETARY AND CONFIDENTIAL</b>	
THE INFORMATION CONTAINED IN THIS DRAWING IS THE SOLE PROPERTY OF G&S INDUSTRIES. ANY REPRODUCTION IN PART OR AS A WHOLE WITHOUT THE WRITTEN PERMISSION OF G&S INDUSTRIES IS PROHIBITED.	
SCALE: AS SHOWN	PRODUCT WEIGHT: 141kg.
PRODUCT FINISH: HOT DIPPED GALVANIZED	
CUSTOMER APPROVAL:	
CUSTOMER NAME / PROJECT:	

NAME	DATE
DRAWN N. A.	14.10.2022
CHECKED S. G.	14.10.2022
APPROVED R. G.	14.10.2022
<b>COPYRIGHT</b>	
THIS DOCUMENT IS PRODUCED BY G&S INDUSTRIES MUST NOT BE COPIED, TRACED, REPRODUCED, OR LENT WITHOUT WRITTEN CONSENT	

PART NUMBER:	<b>MH6BM</b>
TITLE:	<b>6M MEDIUM DUTY MID-HINGED BASE MOUNTED TAPERED OCTAGONAL POLE</b>
SIZE	<b>A4</b>
DWG. NO.	<b>ZLRG2062-1</b>
REV.	<b>0</b>

4

3

2

1