

4

3

2

1

F

F

E

E

D

D

C

C

B

B

A

A

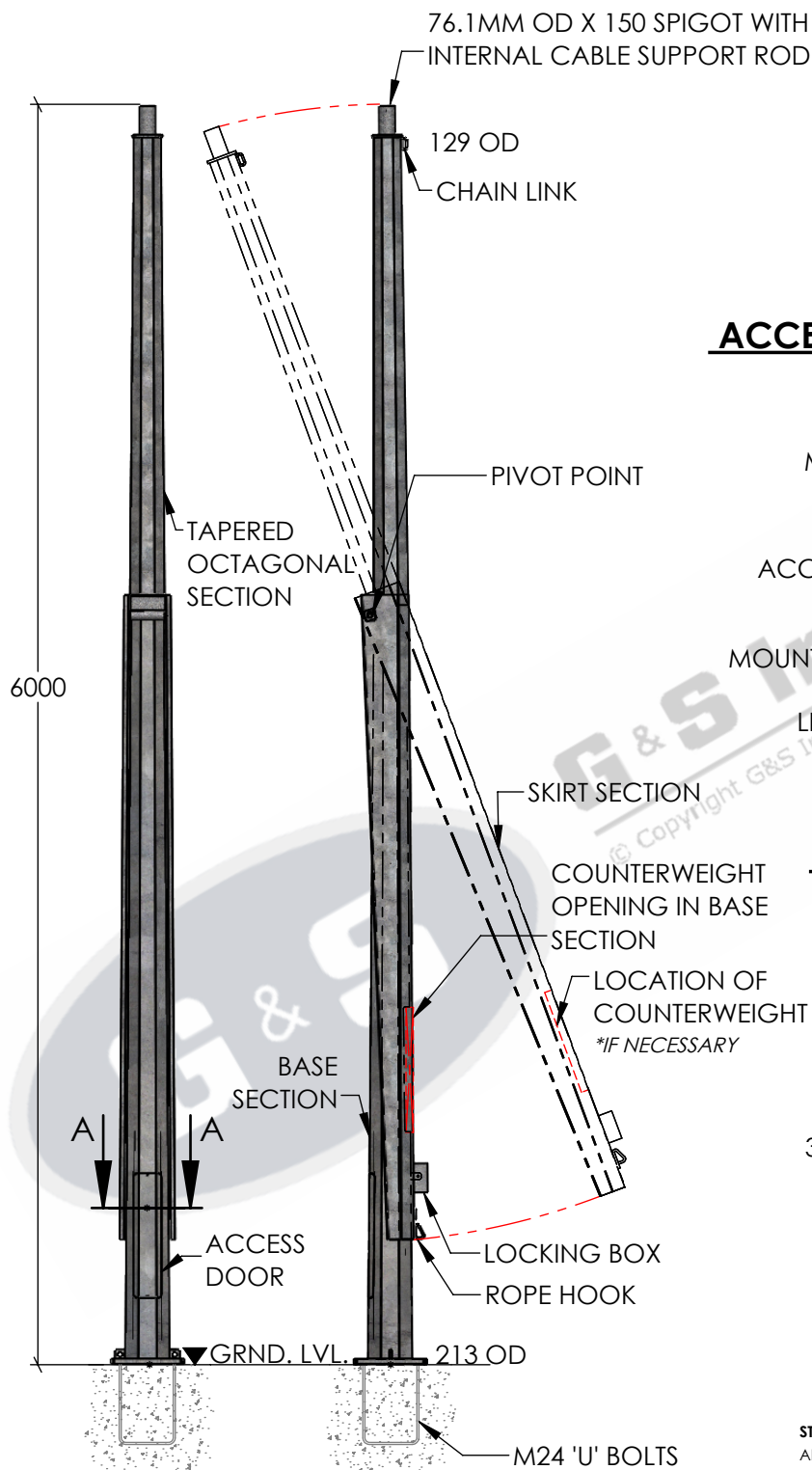

### FRONT & SIDE ELEVATION

SCALE 1:30

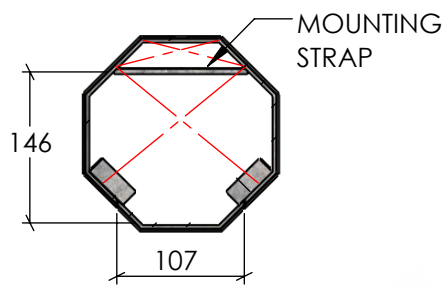

### SECTION A-A ACCESS DOOR CLEARANCE DETAIL

SCALE 1:8

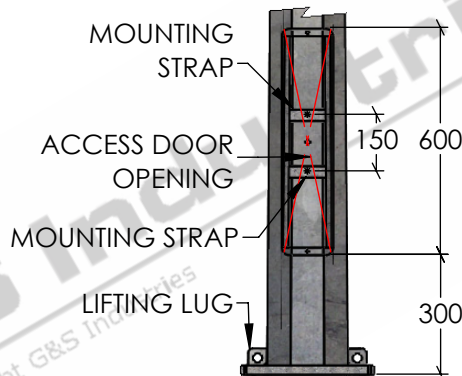

### ELEVATION ON DOOR

SCALE 1:20

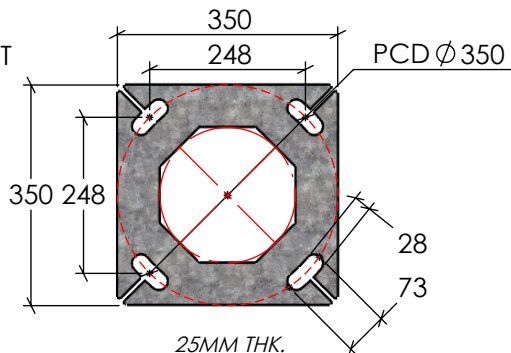

### BASEPLATE DETAILS

SCALE 1:12

#### STANDARDS

- ALL PRODUCTS TO CONFORM TO THE FOLLOWING AUSTRALIAN STANDARDS.
- \* AS 1170.2 Structural design actions - Wind actions.
  - \* AS 1554(set) Structural steel welding set.
  - \* AS 2159: Piling - Design & Installation.
  - \* AS 2870: Residential slab footings - Construction.
  - \* AS 3600: Concrete structures.
  - \* AS 3678: Structural steel - Hot rolled plates, floorplates and slabs.
  - \* AS 4680: Hot dip galvanized (Zinc) Coatings on fabricated ferrous articles.
  - \* AS/NZS 4671: Steel reinforcing materials.
  - \* AS/NZS 4600: Cold formed steel structures.



**G & S Industries**

97 GUTHRIE STREET,  
OSBORNE PARK W.A. 6017  
PH : +6108 9446 8044  
EMAIL: sales@gsindustries.com.au  
WEB: www.gsindustries.com.au

**PROPRIETARY AND CONFIDENTIAL**  
THE INFORMATION CONTAINED IN THIS DRAWING IS THE SOLE PROPERTY OF G&S INDUSTRIES. ANY REPRODUCTION IN PART OR AS A WHOLE WITHOUT THE WRITTEN PERMISSION OF G&S INDUSTRIES IS PROHIBITED.

SCALE: AS SHOWN PRODUCT WEIGHT: 178kg.

PRODUCT FINISH: HOT DIPPED GALVANIZED

CUSTOMER APPROVAL :

CUSTOMER NAME / PROJECT :

	NAME	DATE
DRAWN	N. A.	14.10.2022
CHECKED	S. G.	14.10.2022
APPROVED	R. G.	14.10.2022

**COPYRIGHT**  
THIS DOCUMENT IS PRODUCED BY G&S INDUSTRIES  
MUST NOT BE COPIED, TRACED, REPRODUCED,  
OR LENT WITHOUT WRITTEN CONSENT

PART NUMBER : **MH6BHH**

TITLE :  
**6M EXTRA HEAVY DUTY  
MID-HINGED BASE MOUNTED  
TAPERED OCTAGONAL POLE**

SIZE **A4** DWG. NO. **ZLRG2061A** REV. **0**

SHEET 1 OF 1

4

3

2

1