

4

3

2

1

F

F

E

E

D

D

C

C

B

B

A

A

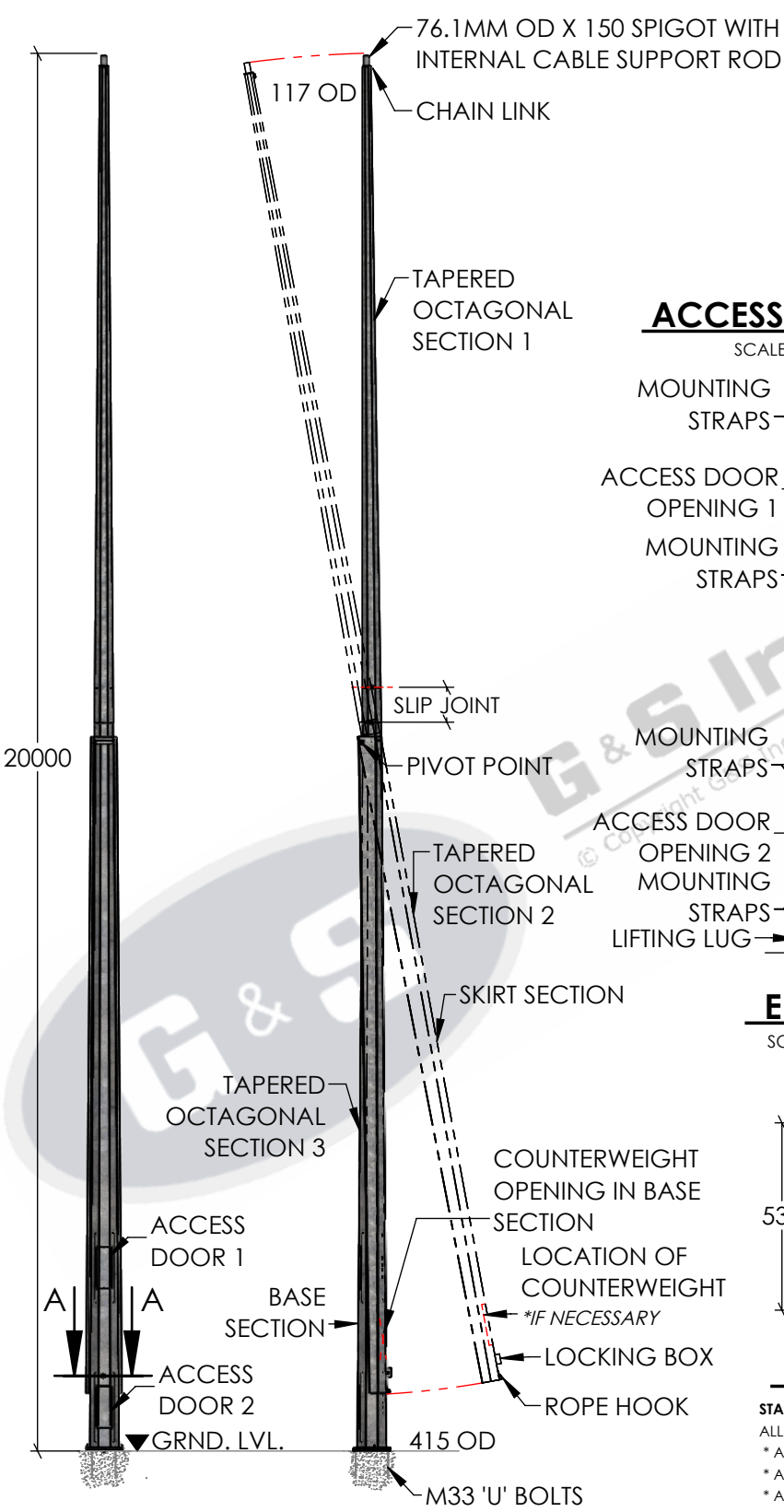

FRONT & SIDE ELEVATION

SCALE 1:100

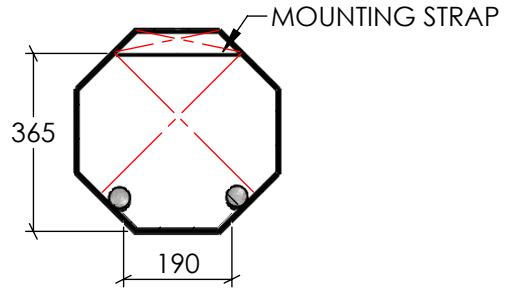

SECTION A-A

ACCESS DOOR CLEARANCE DETAIL

SCALE 1:15

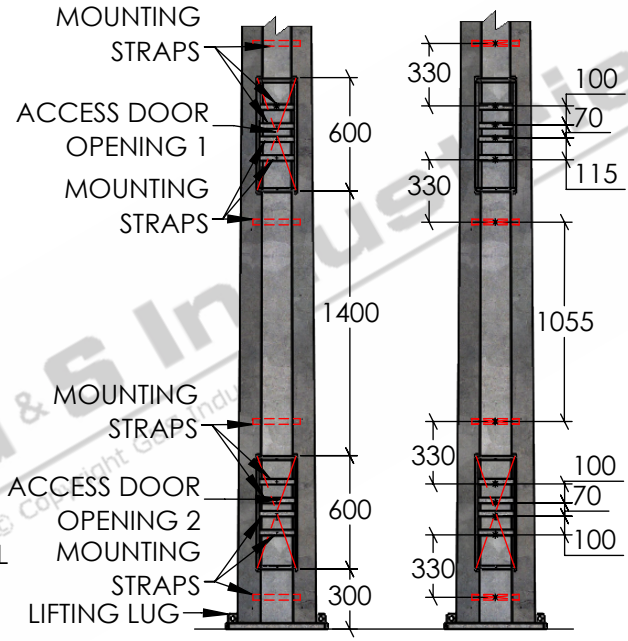

ELEVATION ON DOOR

SCALE 1:30

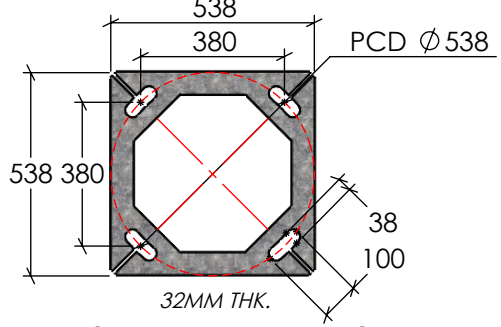

BASEPLATE DETAILS

SCALE 1:20

- STANDARDS**
- ALL PRODUCTS TO CONFORM TO THE FOLLOWING AUSTRALIAN STANDARDS.
- * AS 1170.2 Structural design actions - Wind actions.
 - * AS 1554(set) Structural steel welding set.
 - * AS 2159: Piling - Design & Installation.
 - * AS 2870: Residential slab footings - Construction.
 - * AS 3600: Concrete structures.
 - * AS 3678: Structural steel - Hot rolled plates, floorplates and slabs.
 - * AS 4680: Hot dip galvanized (Zinc) Coatings on fabricated ferrous articles.
 - * AS/NZS 4671: Steel reinforcing materials.
 - * AS/NZS 4600: Cold formed steel structures.



G & S Industries
 97 GUTHRIE STREET,
 OSBORNE PARK W.A. 6017
 PH : +6108 9446 8044
 EMAIL: sales@gsindustries.com.au
 WEB: www.gsindustries.com.au

PROPRIETARY AND CONFIDENTIAL	
THE INFORMATION CONTAINED IN THIS DRAWING IS THE SOLE PROPERTY OF G&S INDUSTRIES. ANY REPRODUCTION IN PART OR AS A WHOLE WITHOUT THE WRITTEN PERMISSION OF G&S INDUSTRIES IS PROHIBITED.	
SCALE: AS SHOWN	PRODUCT WEIGHT: 884kg.
PRODUCT FINISH: HOT DIPPED GALVANIZED	
CUSTOMER APPROVAL:	
CUSTOMER NAME / PROJECT:	

NAME	DATE	PART NUMBER : MH20BM
DRAWN N. A.	14.10.2022	
CHECKED S. G.	14.10.2022	
APPROVED R. G.	14.10.2022	
COPYRIGHT		
THIS DOCUMENT IS PRODUCED BY G&S INDUSTRIES MUST NOT BE COPIED, TRACED, REPRODUCED, OR LENT WITHOUT WRITTEN CONSENT		

SIZE A4	DWG. NO. ZLRG2074	REV. 0
SHEET 1 OF 1		

4

3

2

1