

1 2 3 4 5 6

A

B

C

D

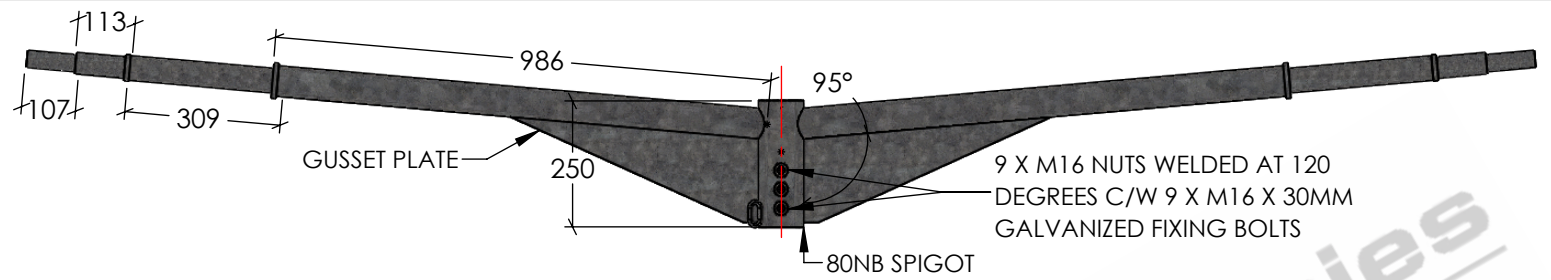

FRONT VIEW

SCALE 1:15

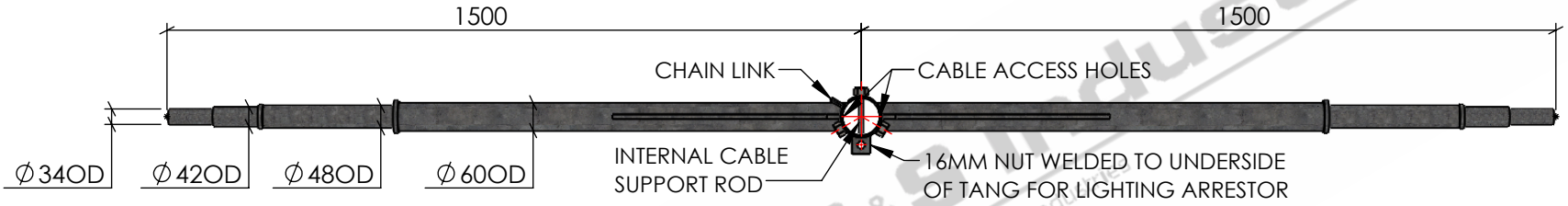

BOTTOM VIEW

SCALE 1:15

NOTE :
CUT BACK TO REQUIRED SPIGOT DIAMETER.

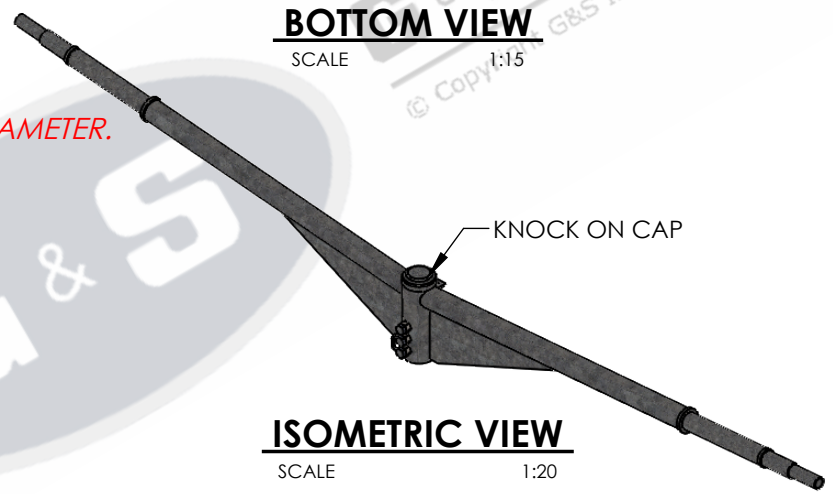

ISOMETRIC VIEW

SCALE 1:20

STANDARDS
 ALL PRODUCTS TO CONFORM TO THE FOLLOWING AUSTRALIAN STANDARDS.
 * AS 1170.2 Structural design actions - Wind actions.
 * AS 1554(set) Structural steel welding set.
 * AS 2159: Piling - Design & Installation.
 * AS 2870: Residential slab footings - Construction.
 * AS 3600: Concrete structures.
 * AS 3678: Structural steel - Hot rolled plates, floorplates and slabs.
 * AS 4680: Hot dip galvanized (Zinc) Coatings on fabricated ferrous articles.
 * AS/NZS 4671: Steel reinforcing materials.
 * AS/NZS 4600: Cold formed steel structures.

G & S Industries
 97 GUTHRIE STREET,
 OSBORNE PARK W.A. 6017
 PH : +6108 9446 8044
 EMAIL: sales@gsindustries.com.au
 WEB: www.gsindustries.com.au

PROPRIETARY AND CONFIDENTIAL		NAME	DATE
THE INFORMATION CONTAINED IN THIS DRAWING IS THE SOLE PROPERTY OF G&S INDUSTRIES. ANY REPRODUCTION IN PART OR AS A WHOLE WITHOUT THE WRITTEN PERMISSION OF G&S INDUSTRIES IS PROHIBITED.		DRAWN	N. A. 14.10.2022
SCALE: AS SHOWN	PRODUCT WEIGHT: 21.3kg.	CHECKED	S. G. 14.10.2022
PRODUCT FINISH: HOT DIPPED GALVANIZED		APPROVED	R. G. 14.10.2022
CUSTOMER APPROVAL:			
CUSTOMER NAME / PROJECT:		COPYRIGHT	
		THIS DOCUMENT IS PRODUCED BY G&S INDUSTRIES. MUST NOT BE COPIED, TRACED, REPRODUCED, OR LENT WITHOUT WRITTEN CONSENT	

PART NUMBER :		HFMULTID1500	
TITLE :		MULTIPLE DIA STREETLIGHTING DOUBLE STRAIGHT 1500MM OUTREACH ARM	
SIZE	DWG. NO.	REV.	
A4	ZLRG2198D	0	

SHEET 1 OF 1	
--------------	--

1 2 3 4 5 6