

**FRONT VIEW**

SCALE 1:8

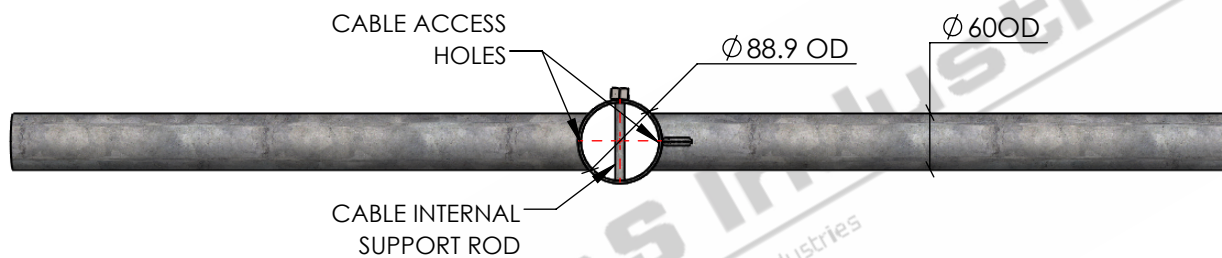

**BOTTOM VIEW**

SCALE 1:8

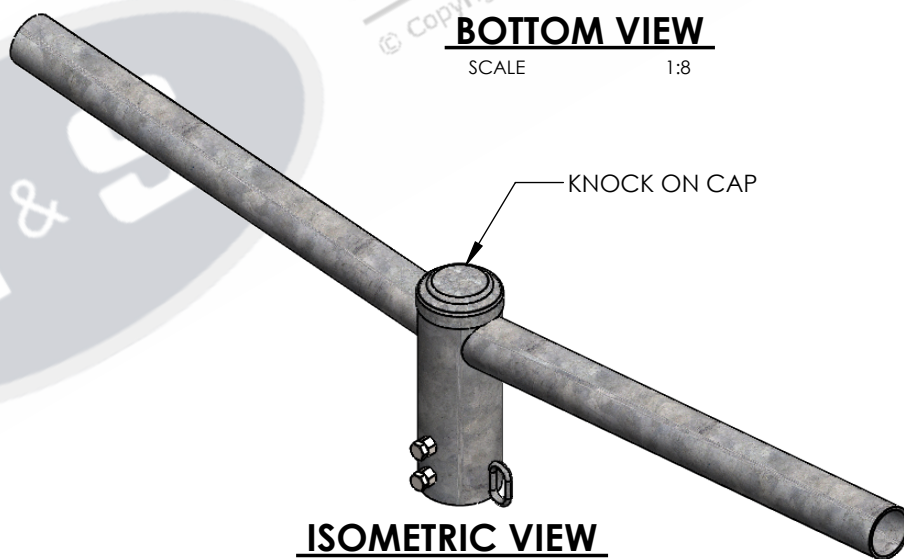

**ISOMETRIC VIEW**

SCALE 1:10

**STANDARDS**

- ALL PRODUCTS TO CONFORM TO THE FOLLOWING AUSTRALIAN STANDARDS.
- \* AS 1170.2 Structural design actions - Wind actions.
  - \* AS 1554(set) Structural steel welding set.
  - \* AS 2159: Piling - Design & Installation.
  - \* AS 2870: Residential slab footings - Construction.
  - \* AS 3600: Concrete structures.
  - \* AS 3678: Structural steel - Hot rolled plates, floorplates and slabs.
  - \* AS 4680: Hot dip galvanized (Zinc) Coatings on fabricated ferrous articles.
  - \* AS/NZS 4671: Steel reinforcing materials.
  - \* AS/NZS 4600: Cold formed steel structures.



**G & S Industries**

97 GUTHRIE STREET,  
OSBORNE PARK W.A. 6017  
PH : +6108 9446 8044  
EMAIL: sales@gsindustries.com.au  
WEB: www.gsindustries.com.au

|   |                        |
|---|------------------------|
| <b>PROPRIETARY AND CONFIDENTIAL</b>   |                        |
| THE INFORMATION CONTAINED IN THIS DRAWING IS THE SOLE PROPERTY OF G&S INDUSTRIES . ANY REPRODUCTION IN PART OR AS A WHOLE WITHOUT THE WRITTEN PERMISSION OF G&S INDUSTRIES IS PROHIBITED. |                        |
| SCALE: AS SHOWN   | PRODUCT WEIGHT: 8.5kg. |
| PRODUCT FINISH: HOT DIPPED GALVANIZED   |                        |
| CUSTOMER APPROVAL :   |                        |
| CUSTOMER NAME / PROJECT :   |                        |

|   |                              |            |   |
|---|------------------------------|------------|---|
|   | NAME                         | DATE       | PART NUMBER :<br><b>HF/60/D/600</b>   |
| DRAWN   | N. A.                        | 14.10.2022 |   |
| CHECKED   | S. G.                        | 14.10.2022 |   |
| APPROVED  | R. G.                        | 14.10.2022 |   |
| <b>COPYRIGHT</b>  |                              |            | TITLE :<br><b>600D STREETLIGHTING<br/>DOUBLE HEADFRAME<br/>WITH 600MM OUTREACH ARMS</b> |
| THIS DOCUMENT IS PRODUCED BY G&S INDUSTRIES<br>MUST NOT BE COPIED, TRACED, REPRODUCED,<br>OR LENT WITHOUT WRITTEN CONSENT |                              |            |   |
| SIZE<br><b>A4</b>   | DWG. NO.<br><b>ZLRG2198B</b> |            | REV.<br><b>0</b>  |