

4

3

2

1

F

F

E

E

D

D

C

C

B

B

A

A

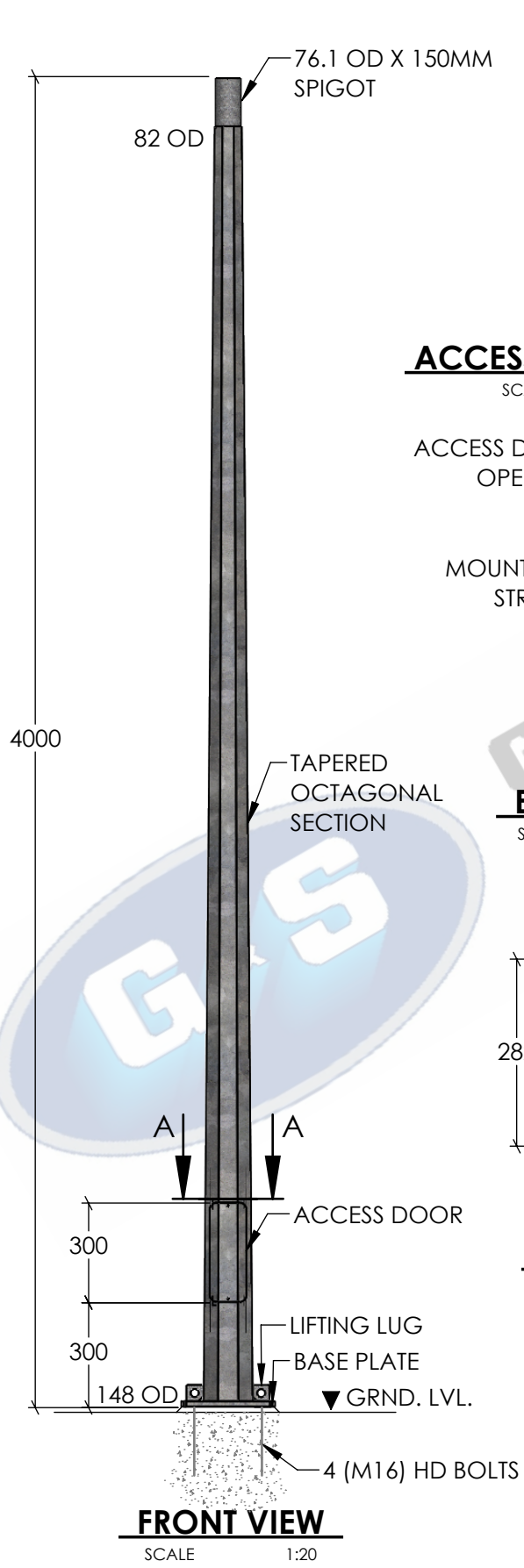

FRONT VIEW
SCALE 1:20

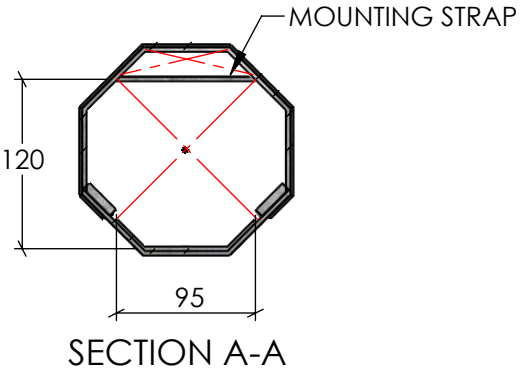

SECTION A-A
ACCESS DOOR CLEARANCE DETAIL
SCALE 1:5

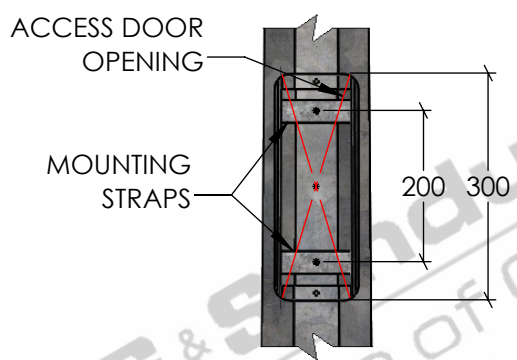

**DOOR REMOVED FOR CLARITY*
ELEVATION ON DOOR
SCALE 1:10

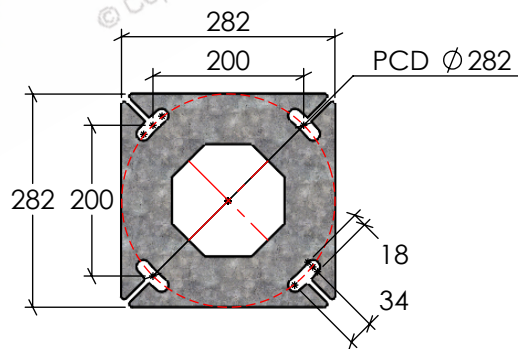

16MM THK.
BASEPLATE DETAILS
SCALE 1:10

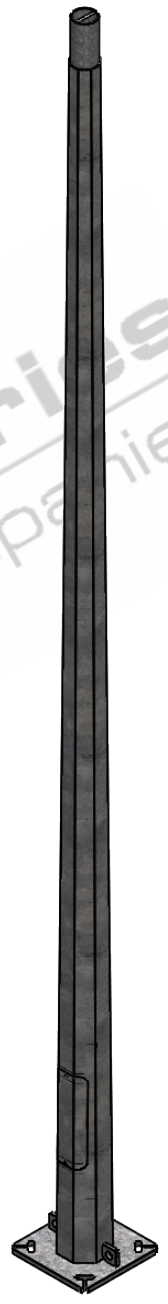

ISOMETRIC DETAIL
SCALE 1:20

- STANDARDS
ALL PRODUCTS TO CONFORM TO THE FOLLOWING AUSTRALIAN STANDARDS
- * AS 1554(set) Structural steel welding set.
 - * AS 2159: Piling - Design & Installation.
 - * AS 2870: Residential slab footings - Construction.
 - * AS 3600: Concrete structures.
 - * AS 3678: Structural steel - Hot rolled plates, floorplates and slabs.
 - * AS 4680: Hot dip galvanized (Zinc) Coatings on fabricated ferrous articles.
 - * AS/NZS 4671: Steel reinforcing materials.
 - * AS/NZS 4676: Structural design requirements for utility services poles.

G&S Industries
Group of Companies
97 GUTHRIE STREET,
OSBORNE PARK W.A. 6017
PH : +6108 9446 8044
EMAIL: sales@gsindustries.com.au
WEB: www.gsindustries.com.au

PROPRIETARY AND CONFIDENTIAL
THE INFORMATION CONTAINED IN THIS DRAWING IS THE SOLE PROPERTY OF G&S INDUSTRIES. ANY REPRODUCTION IN PART OR AS A WHOLE WITHOUT THE WRITTEN PERMISSION OF G&S INDUSTRIES IS PROHIBITED.

SCALE: AS SHOWN

PRODUCT FINISH: H.D.G (HOT DIPPED GALVANIZED) PRODUCT WEIGHT: 46kg.

CUSTOMER APPROVAL:

CUSTOMER NAME / PROJECT:

	NAME	DATE
DRAWN	N.C. A.	04.06.2020
CHECKED	RG	04.06.2020
REVISED	N.C. A.	30.06.2020
COPYRIGHT		
THIS DOCUMENT IS PRODUCED BY G&S INDUSTRIES MUST NOT BE COPIED, TRACED, REPRODUCED, OR LENT WITHOUT WRITTEN CONSENT		

PART NUMBER :		F4BM
TITLE :		4M MEDIUM DUTY FIXED BASE MOUNTED TAPERED OCTAGONAL POLE
SIZE	DWG. NO.	REV.
A4	ZLRG2036CA	0
SHEET 1 OF 1		

4

3

2

1