

**TOP VIEW**

SCALE 1:25

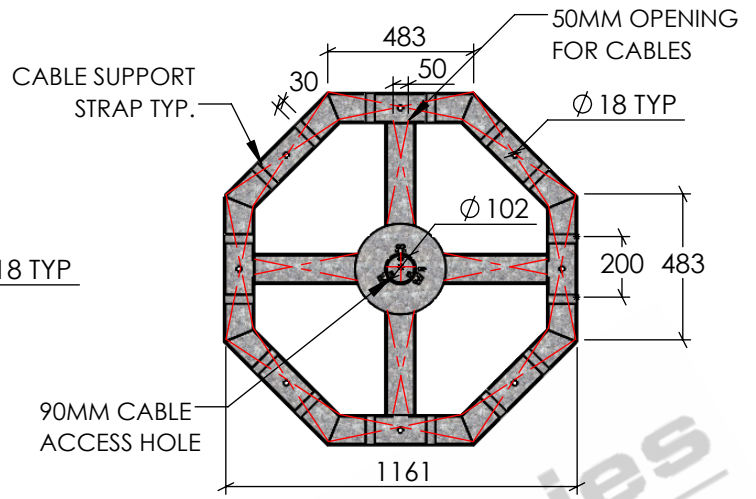

**BOTTOM VIEW**

SCALE 1:25

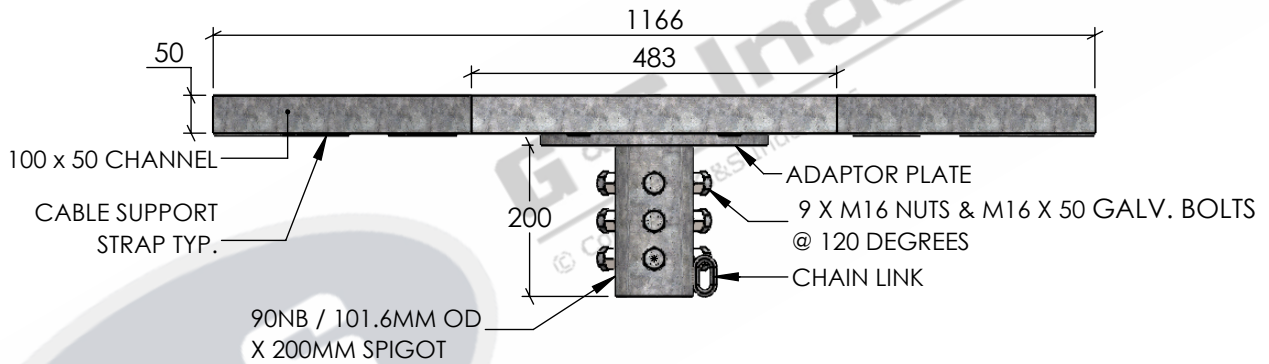

**ISOMETRIC VIEW**

SCALE 1:10

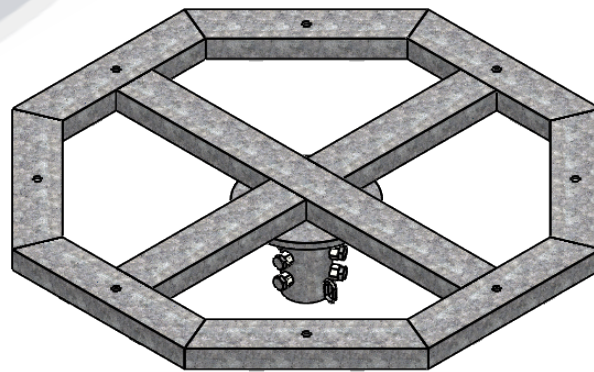

**ISOMETRIC VIEW**

SCALE 1:15

**STANDARDS**

ALL PRODUCTS TO CONFORM TO THE FOLLOWING AUSTRALIAN STANDARDS.

- \* AS 1170.2 Structural design actions - Wind actions.
- \* AS 3678: Structural steel - Hot rolled plates, floorplates and slabs.
- \* AS 1554(set) Structural steel welding set.
- \* AS 4680: Hot dip galvanized (Zinc) Coatings on fabricated ferrous articles.
- \* AS 2159: Piling - Design & Installation.
- \* AS/NZS 4671: Steel reinforcing materials.
- \* AS 2870: Residential slab footings - Construction.
- \* AS/NZS 4600: Cold formed steel structures.
- \* AS 3600: Concrete structures.

|   |   |   |          |       |                                  |   |
|---|---|---|----------|-------|----------------------------------|---|
|  <p><b>G &amp; S Industries</b><br/>97 GUTHRIE STREET,<br/>OSBORNE PARK W.A. 6017<br/>PH : +6108 9446 8044<br/>EMAIL: sales@gsindustries.com.au<br/>WEB: www.gsindustries.com.au</p> | <b>PROPRIETARY AND CONFIDENTIAL</b>   |   | NAME     | DATE  | PART NUMBER :<br><b>CA8WAYT8</b> |   |
|   | THE INFORMATION CONTAINED IN THIS DRAWING IS THE SOLE PROPERTY OF G&S INDUSTRIES . ANY REPRODUCTION IN PART OR AS A WHOLE WITHOUT THE WRITTEN PERMISSION OF G&S INDUSTRIES IS PROHIBITED. |   | DRAWN    | N. A. |                                  | 14.10.2022  |
|   | SCALE: AS SHOWN   | PRODUCT WEIGHT: 58kg.   | APPROVED | S. G. | 14.10.2022                       | TITLE :<br><b>8 WAY CROSSARM TO SUIT TRUNION MOUNTED LIGHTS</b> |
|   | PRODUCT FINISH: HOT DIPPED GALVANIZED   |   |          | R. G. | 14.10.2022                       |   |
| CUSTOMER APPROVAL :   |   | <b>COPYRIGHT</b>  |          |       | SIZE DWG. NO.                    |   |
| CUSTOMER NAME / PROJECT :   |   | THIS DOCUMENT IS PRODUCED BY G&S INDUSTRIES MUST NOT BE COPIED, TRACED, REPRODUCED, OR LENT WITHOUT WRITTEN CONSENT |          |       | <b>ZLRG2181</b>                  |   |
|   |   |   |          |       | REV. <b>0</b>                    |   |
|   |   |   |          |       | SHEET 1 OF 1                     |   |