

4

3

2

1

F

F

E

E

D

D

C

C

B

B

A

A

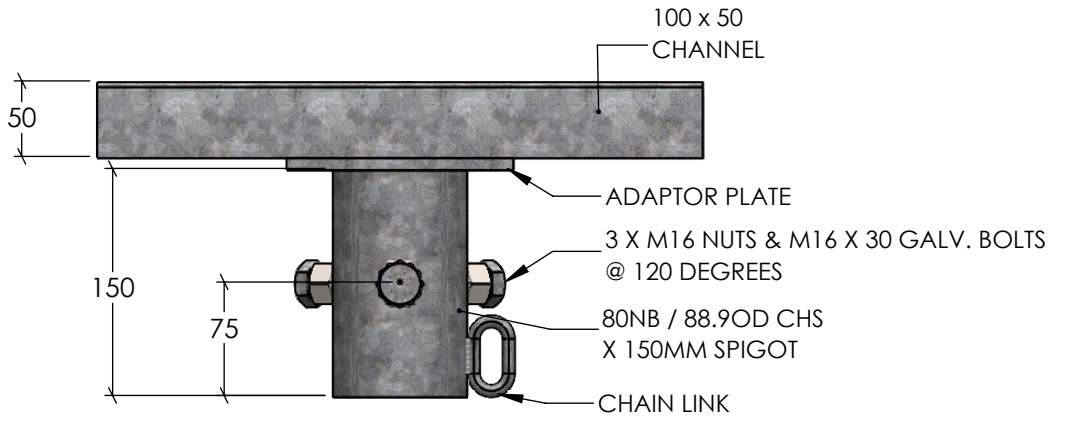

SIDE VIEW

SCALE 1:5

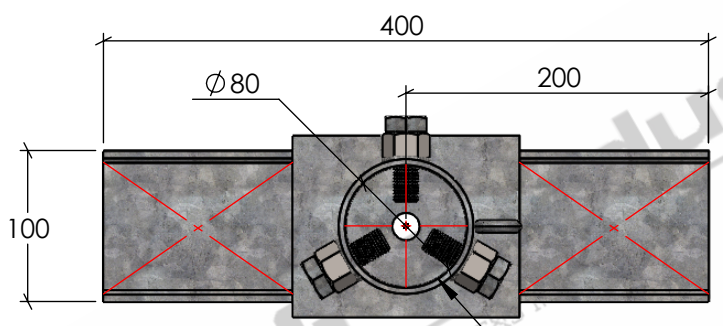

BOTTOM VIEW

SCALE 1:5

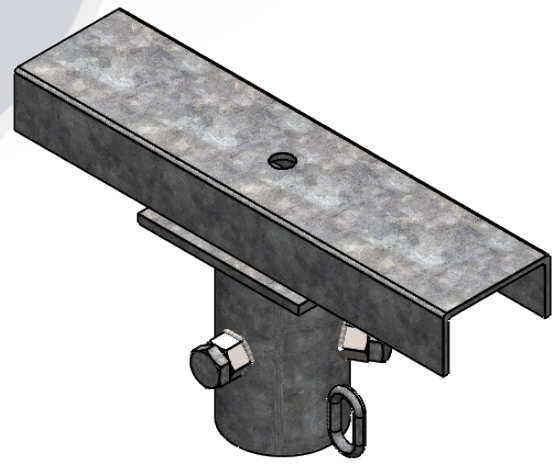

ISOMETRIC VIEW

SCALE 1:5

STANDARDS

- ALL PRODUCTS TO CONFORM TO THE FOLLOWING AUSTRALIAN STANDARDS.
- * AS 1170.2 Structural design actions - Wind actions.
 - * AS 3678: Structural steel - Hot rolled plates, floorplates and slabs.
 - * AS 1554(set) Structural steel welding set.
 - * AS 4680: Hot dip galvanized (Zinc) Coatings on fabricated ferrous articles.
 - * AS 2159: Piling - Design & Installation.
 - * AS/NZS 4671: Steel reinforcing materials.
 - * AS 2870: Residential slab footings - Construction.
 - * AS/NZS 4600: Cold formed steel structures.
 - * AS 3600: Concrete structures.



G & S Industries
 97 GUTHRIE STREET,
 OSBORNE PARK W.A. 6017
 PH : +6108 9446 8044
 EMAIL: sales@gsindustries.com.au
 WEB: www.gsindustries.com.au

| | |
|--|------------------------|
| PROPRIETARY AND CONFIDENTIAL | |
| THE INFORMATION CONTAINED IN THIS DRAWING IS THE SOLE PROPERTY OF G&S INDUSTRIES. ANY REPRODUCTION IN PART OR AS A WHOLE WITHOUT THE WRITTEN PERMISSION OF G&S INDUSTRIES IS PROHIBITED. | |
| SCALE: AS SHOWN | PRODUCT WEIGHT: 5.2kg. |
| PRODUCT FINISH: HOT DIPPED GALVANIZED | |
| CUSTOMER APPROVAL: | |
| CUSTOMER NAME / PROJECT: | |

| | | |
|---|-------|------------|
| | NAME | DATE |
| DRAWN | N. A. | 14.10.2022 |
| CHECKED | S. G. | 14.10.2022 |
| APPROVED | R. G. | 14.10.2022 |
| COPYRIGHT | | |
| THIS DOCUMENT IS PRODUCED BY G&S INDUSTRIES MUST NOT BE COPIED, TRACED, REPRODUCED, OR LENT WITHOUT WRITTEN CONSENT | | |

| | | |
|---------------|---|----------|
| PART NUMBER : | CA400T1 | |
| TITLE : | 400MM CROSSARM TO FIT TRUNION MOUNTED LIGHTS | |
| SIZE | DWG. NO. | REV. |
| A4 | ZLRG2168 | 0 |

4

3

2

1