

4 3 2 1

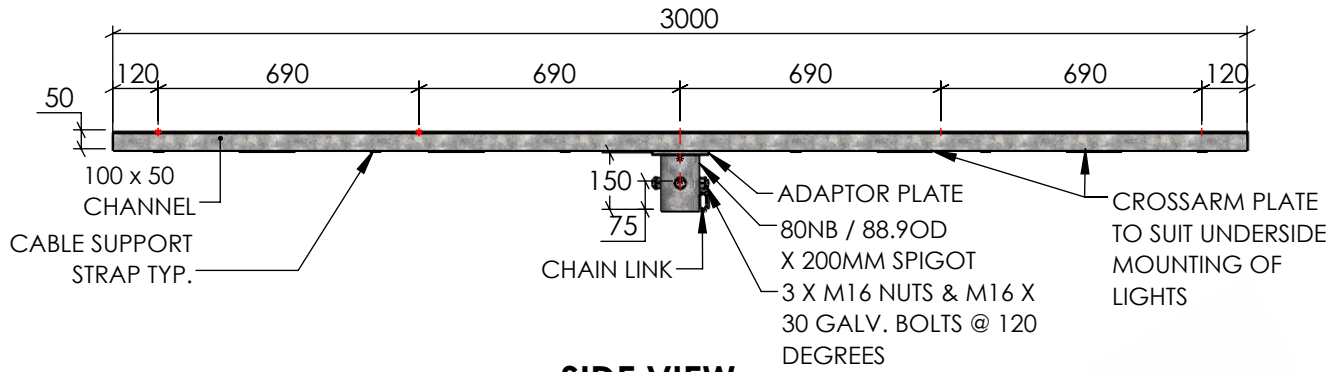

SIDE VIEW
SCALE 1:15

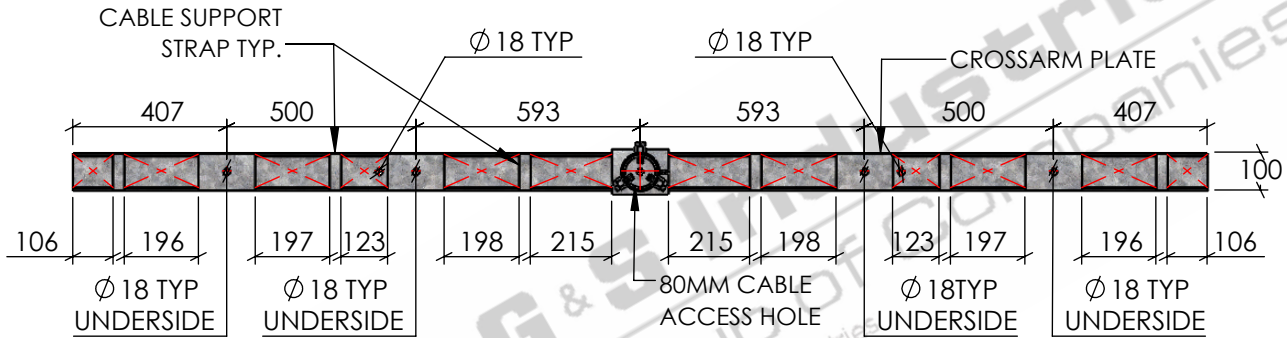

BOTTOM VIEW
SCALE 1:15

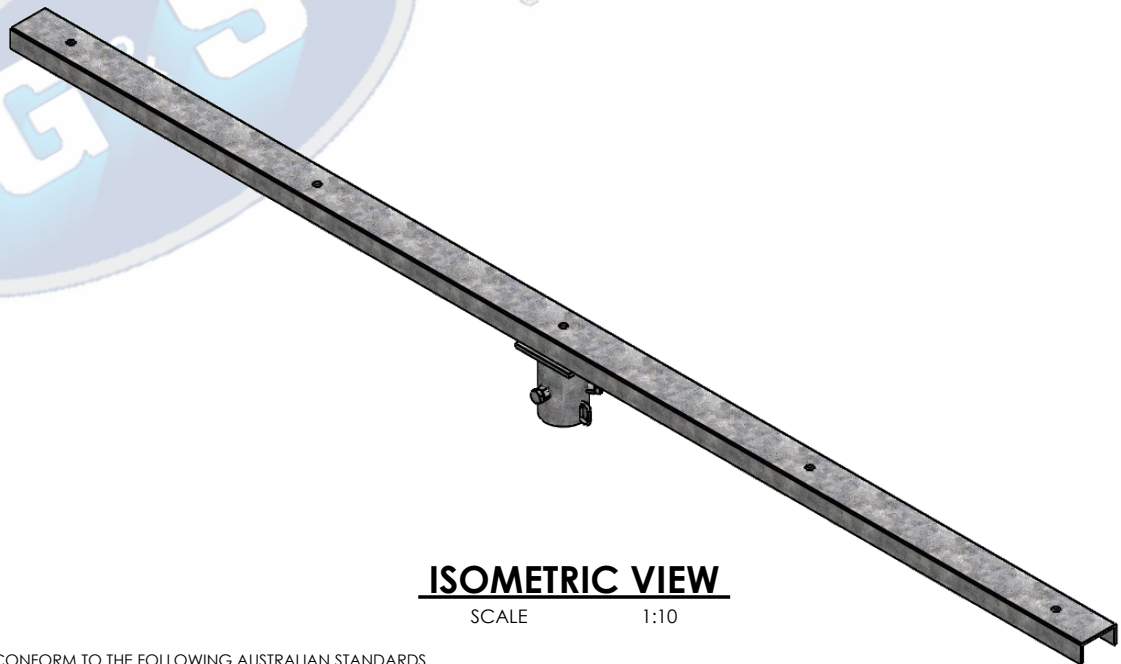

ISOMETRIC VIEW
SCALE 1:10

STANDARDS

- ALL PRODUCTS TO CONFORM TO THE FOLLOWING AUSTRALIAN STANDARDS
- * AS 1554(set) Structural steel welding set.
 - * AS 2159: Piling - Design & Installation.
 - * AS 2870: Residential slab footings - Construction.
 - * AS 3600: Concrete structures.
 - * AS 3678: Structural steel - Hot rolled plates, floorplates and slabs.
 - * AS 4680: Hot dip galvanized (Zinc) Coatings on fabricated ferrous articles.
 - * AS/NZS 4671: Steel reinforcing materials.
 - * AS/NZS 4676: Structural design requirements for utility services poles.

PROPRIETARY AND CONFIDENTIAL	
THE INFORMATION CONTAINED IN THIS DRAWING IS THE SOLE PROPERTY OF G&S INDUSTRIES. ANY REPRODUCTION IN PART OR AS A WHOLE WITHOUT THE WRITTEN PERMISSION OF G&S INDUSTRIES IS PROHIBITED.	
SCALE: AS SHOWN	PRODUCT WEIGHT: 36kg.
PRODUCT FINISH: H.D.G (HOT DIPPED GALVANIZED)	CUSTOMER APPROVAL:
CUSTOMER NAME / PROJECT:	

NAME	DATE
DRAWN N.C. A.	04.06.2020
CHECKED RG	04.06.2020
REVISED N.C. A.	30.06.2020
COPYRIGHT	
THIS DOCUMENT IS PRODUCED BY G&S INDUSTRIES MUST NOT BE COPIED, TRACED, REPRODUCED, OR LENT WITHOUT WRITTEN CONSENT	

PART NUMBER :	CA3000T5OR8
TITLE :	3000MM CROSSARM SUIT 5 OR 8 TRUNION MOUNTED LIGHTS
SIZE DWG. NO.	A4 ZLRG2183
REV.	0

G&S Industries
Group of Companies
97 GUTHRIE STREET,
OSBORNE PARK W.A. 6017
PH : +6108 9446 8044
EMAIL: sales@gsindustries.com.au
WEB: www.gsindustries.com.au

4 3 2 1