

4

3

2

1

F

F

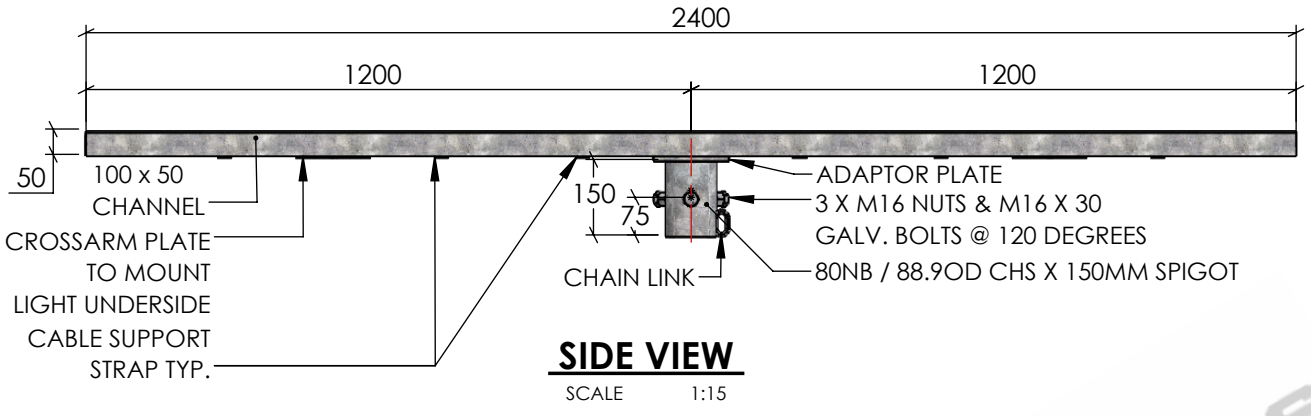

E

E

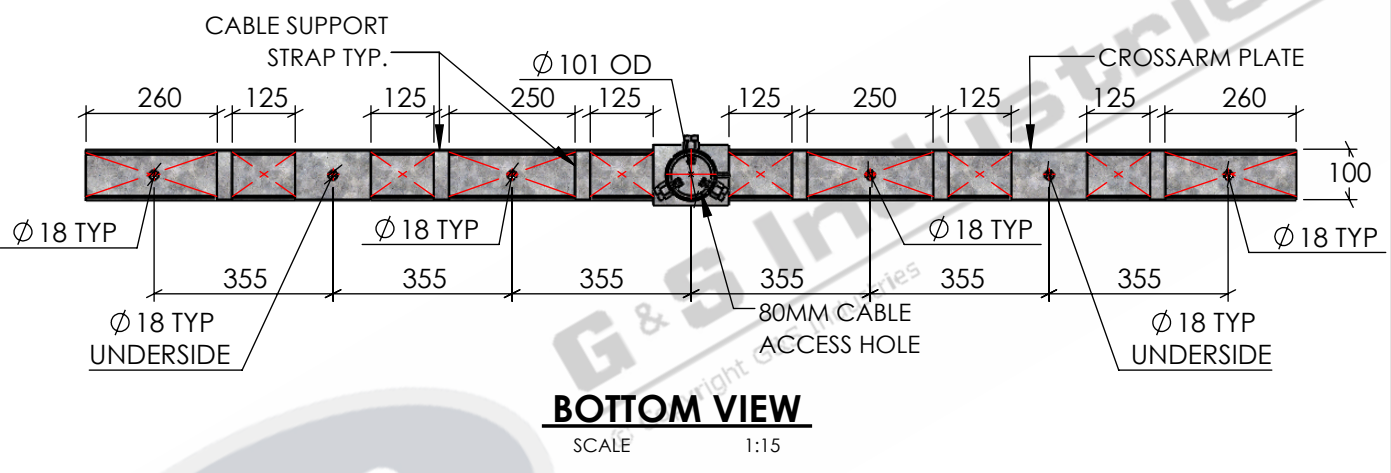

D

D

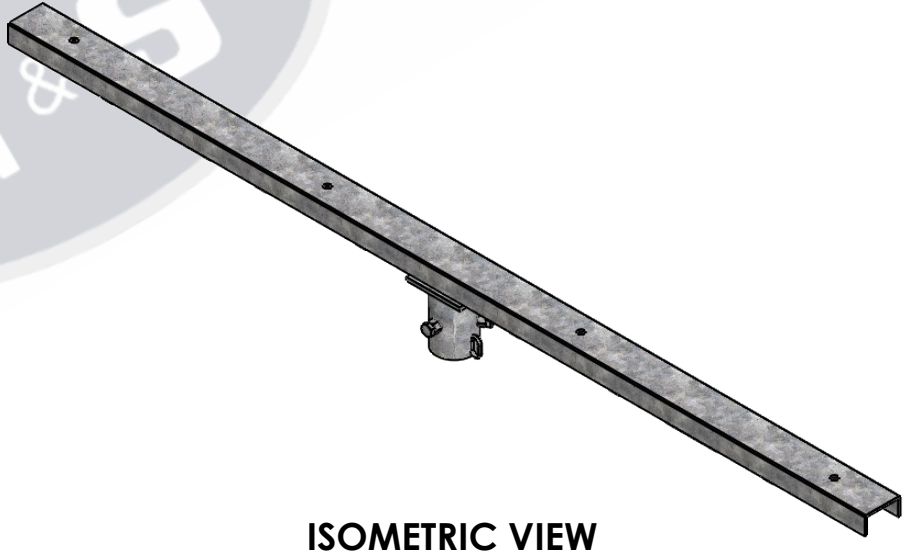

B

B

**STANDARDS**

- ALL PRODUCTS TO CONFORM TO THE FOLLOWING AUSTRALIAN STANDARDS.
- \* AS 1170.2 Structural design actions - Wind actions.
  - \* AS 3678: Structural steel - Hot rolled plates, floorplates and slabs.
  - \* AS 1554(set) Structural steel welding set.
  - \* AS 4680: Hot dip galvanized (Zinc) Coatings on fabricated ferrous articles.
  - \* AS 2159: Piling - Design & Installation.
  - \* AS/NZS 4671: Steel reinforcing materials.
  - \* AS 2870: Residential slab footings - Construction.
  - \* AS/NZS 4600: Cold formed steel structures.
  - \* AS 3600: Concrete structures.

A

A

 <p><b>G &amp; S Industries</b> 97 GUTHRIE STREET, OSBORNE PARK W.A. 6017 PH : +6108 9446 8044 EMAIL: sales@gsindustries.com.au WEB: www.gsindustries.com.au</p>	<b>PROPRIETARY AND CONFIDENTIAL</b>		NAME	DATE	PART NUMBER : <b>CA2400T4OR6</b>	
	THE INFORMATION CONTAINED IN THIS DRAWING IS THE SOLE PROPERTY OF G&S INDUSTRIES . ANY REPRODUCTION IN PART OR AS A WHOLE WITHOUT THE WRITTEN PERMISSION OF G&S INDUSTRIES IS PROHIBITED.		DRAWN	N. A.		14.10.2022
	SCALE: <b>AS SHOWN</b>	PRODUCT WEIGHT:	CHECKED	S. G.	14.10.2022	TITLE : <b>2400 CROSSARM TO SUIT 4 OR 6 TRUNION MOUNTED LIGHTS</b>
	PRODUCT FINISH: <b>HOT DIPPED GALVANIZED</b>	26.6kg.	APPROVED	R. G.	14.10.2022	
	CUSTOMER APPROVAL :					
CUSTOMER NAME / PROJECT :		<b>COPYRIGHT</b>		THIS DOCUMENT IS PRODUCED BY G&S INDUSTRIES MUST NOT BE COPIED, TRACED, REPRODUCED, OR LENT WITHOUT WRITTEN CONSENT	SIZE <b>A4</b> DWG. NO. <b>ZLRG2177</b> REV. <b>0</b>	
					SHEET 1 OF 1	

4

3

2

1