

4

3

2

1

F

F

E

E

D

D

C

C

B

B

A

A

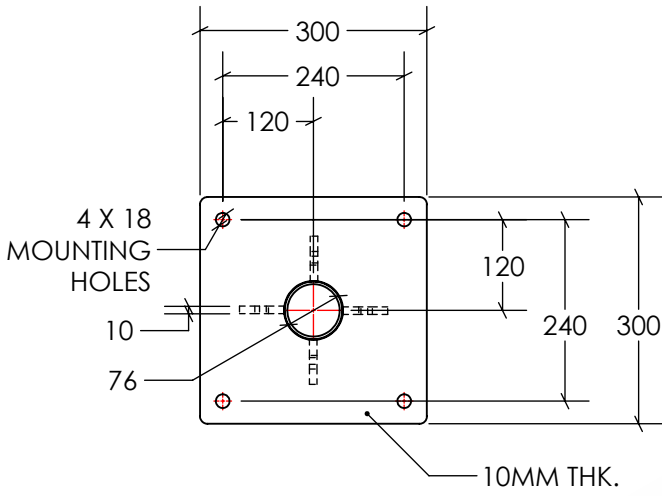

TOP VIEW
SCALE 1:10

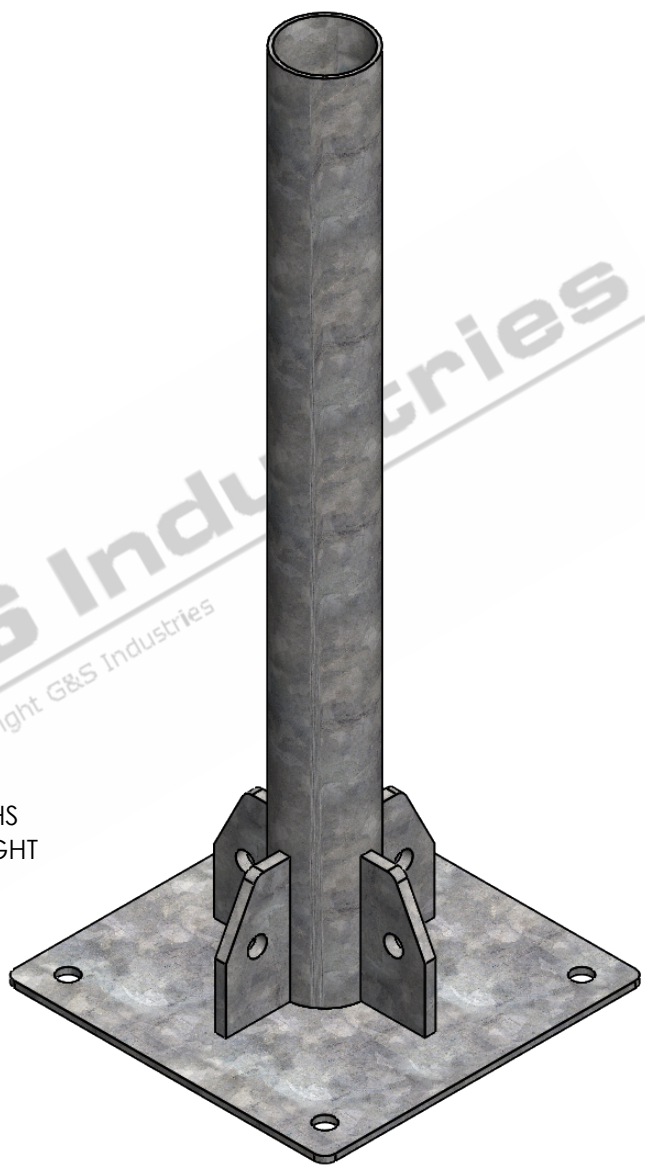

ISOMETRIC ELEVATION
SCALE 1:5

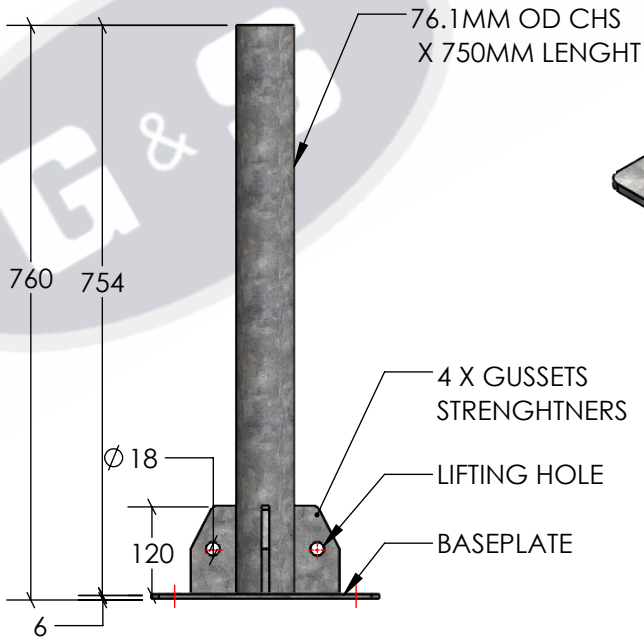

SIDE ELEVATION
SCALE 1:10

STANDARDS

- ALL PRODUCTS TO CONFORM TO THE FOLLOWING AUSTRALIAN STANDARDS.
- * AS 1170.2 Structural design actions - Wind actions.
 - * AS 1554(set) Structural steel welding set.
 - * AS 2159: Piling - Design & Installation.
 - * AS 2870: Residential slab footings - Construction.
 - * AS 3600: Concrete structures.
 - * AS 3678: Structural steel - Hot rolled plates, floorplates and slabs.
 - * AS 4680: Hot dip galvanized (Zinc) Coatings on fabricated ferrous articles.
 - * AS/NZS 4671: Steel reinforcing materials.
 - * AS/NZS 4600: Cold formed steel structures.



G & S Industries
97 GUTHRIE STREET,
OSBORNE PARK W.A. 6017
PH : +6108 9446 8044
EMAIL: sales@gsindustries.com.au
WEB: www.gsindustries.com.au

PROPRIETARY AND CONFIDENTIAL
THE INFORMATION CONTAINED IN THIS DRAWING IS THE SOLE PROPERTY OF G&S INDUSTRIES. ANY REPRODUCTION IN PART OR AS A WHOLE WITHOUT THE WRITTEN PERMISSION OF G&S INDUSTRIES IS PROHIBITED.

SCALE: AS SHOWN PRODUCT WEIGHT: 13.7kg.
PRODUCT FINISH: HOT DIPPED GALVANIZED

CUSTOMER APPROVAL :
CUSTOMER NAME / PROJECT :

	NAME	DATE
DRAWN	N. A.	14.10.2022
CHECKED	S. G.	14.10.2022
APPROVED	R. G.	14.10.2022

COPYRIGHT
THIS DOCUMENT IS PRODUCED BY G&S INDUSTRIES
MUST NOT BE COPIED, TRACED, REPRODUCED,
OR LENT WITHOUT WRITTEN CONSENT

PART NUMBER :	BM01
TITLE :	BUILDING MOUNT BRACKET SUIT CCTV/COMMS/LIGHTING (VERTICAL OR HORIZONTAL MOUNTING)
SIZE	DWG. NO.
A4	ZLRG2543
REV.	0

4

3

2

1