

1

2

3

4

A

A

B

B

C

C

D

D

E

E

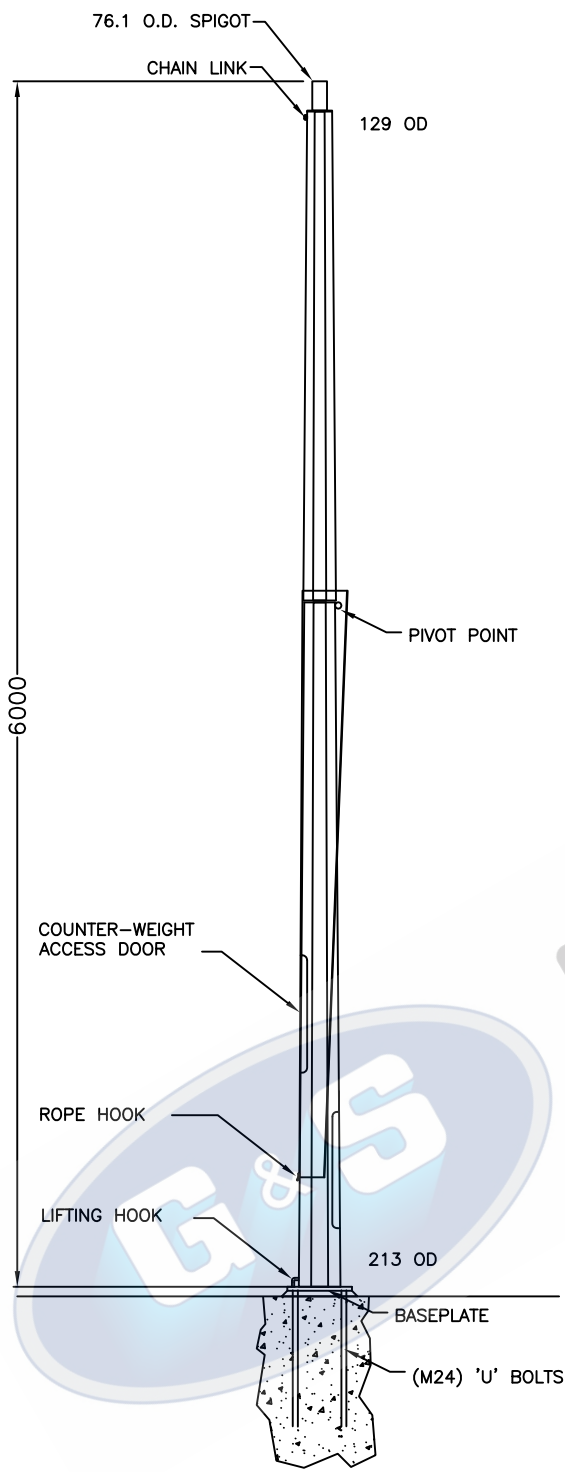

ELEVATION

TOTAL WEIGHT OF COLUMN: 190KG'S

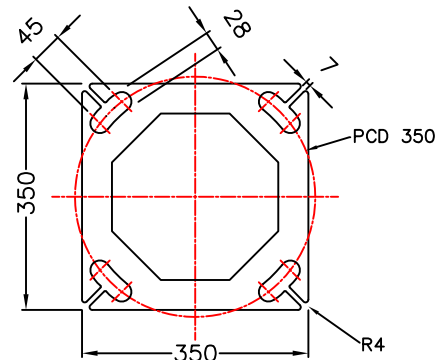

BASEPLATE THICKNESS: 25mm
BASEPLATE DETAILS

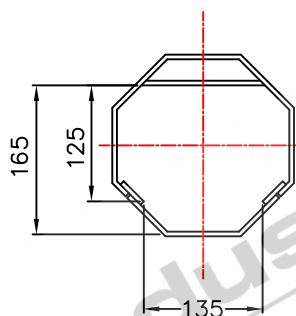

CONTROL GEAR CLEARANCE DETAILS

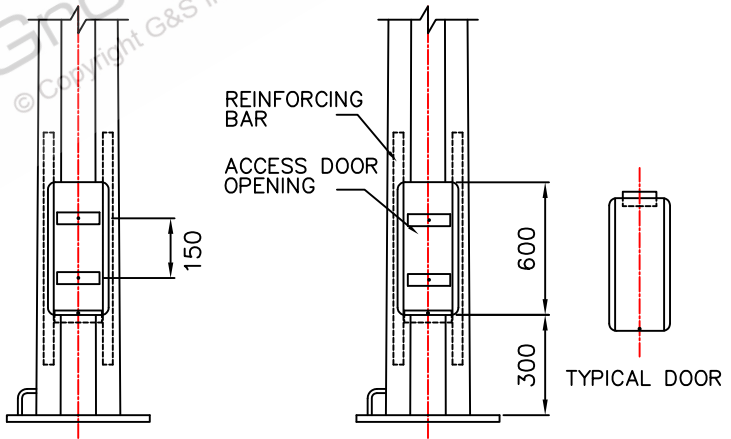

ELEVATION ON DOOR
DOOR REMOVED FOR CLARITY



G&S Industries
Group of Companies

Client Drawing Approval
To Commence Production

Client Name: _____
Authorized Person: _____

Signature: _____ Date Authorized: _____

- STANDARDS**
ALL PRODUCTS TO CONFORM TO THE FOLLOWING AUSTRALIAN STANDARDS
- AS 1170.2: Structural design actions – Wind actions.
 - AS 1302: Geometrical product specifications indication of surface texture in technical production documentation.
 - AS 1554(set): Structural steel welding set.
 - AS 2159: Piling – Design & Installation.
 - AS 2870: Residential slab footings – Construction.
 - AS 3600: Concrete structures.
 - AS 3678: Structural steel – Hot rolled plates, floorplates and slabs.
 - AS 4680: Hot dip galvanized (Zinc) Coatings on fabricated ferrous articles.
 - AS/NZS 4671: Steel reinforcing materials.
 - AS/NZS 4600: Cold formed steel structures.
 - AS/NZS 4676: Structural design requirements for utility services poles.



G&S Industries

97 GUTHRIE STREET, OSBORNE PARK W.A. 6017
PH (08) 9446 8044. (08) 9446 8266
FAX (08) 9446 5456

JOB NO.	DATE:	DESIGN:	DRAWN:
6M MID-HINGED TAPERED OCTAGONAL COLUMN MH6BHH 630003B		S.G.	Z.L.
		CHECKED:	APPROVED:
		R.G.	Y
		LAST REVISED:	SCALE:
		13 JUN '06	NTS
		DRAWING:	REVISION:
		ZLRG2061A	01

1

2

3

4