

1

2

3

4

A

A

B

B

C

C

D

D

E

E

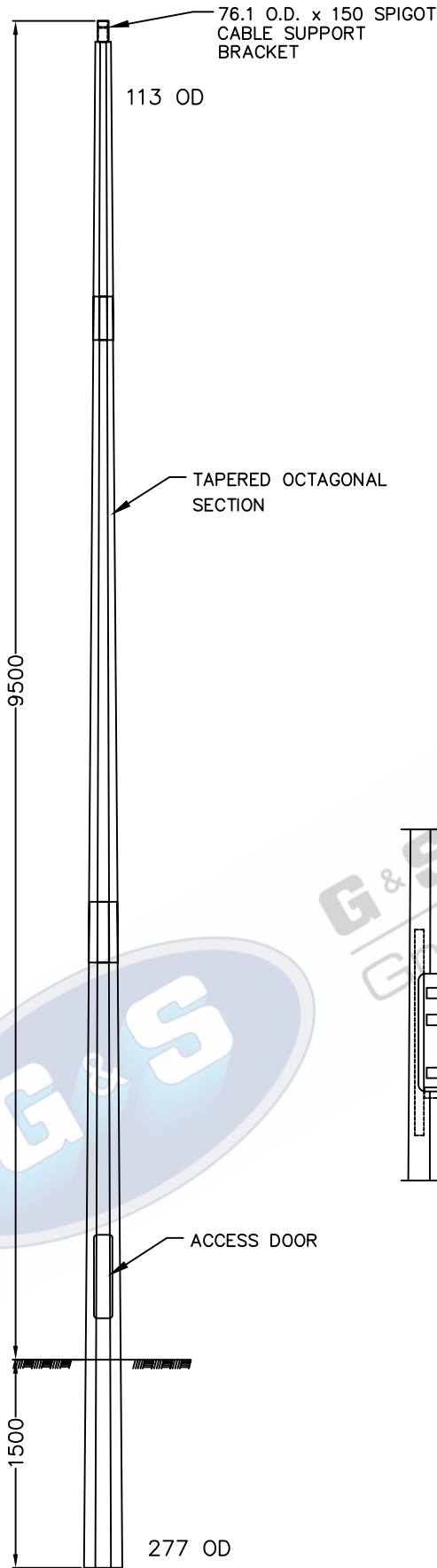

ELEVATION

TOTAL WEIGHT OF COLUMN: 235.00KG'S

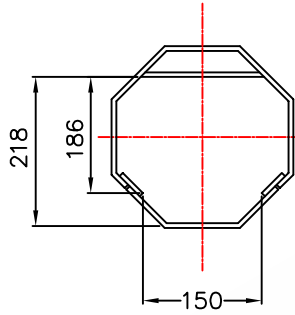

CONTROL GEAR CLEARANCE DETAILS

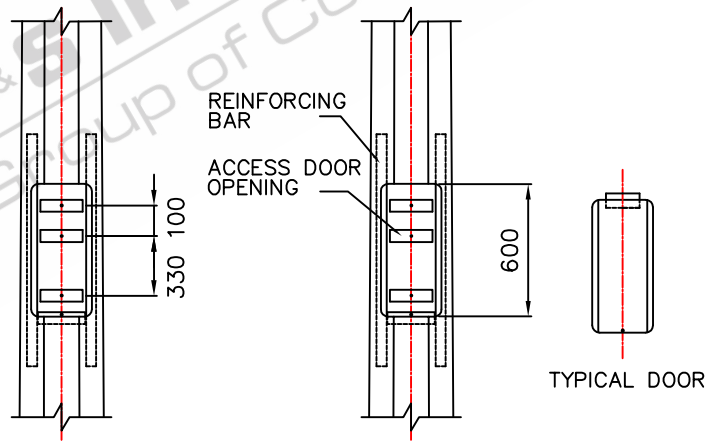

ELEVATION ON DOOR
DOOR REMOVED FOR CLARITY

STANDARDS

- ALL PRODUCTS TO CONFORM TO THE FOLLOWING AUSTRALIAN STANDARDS
- * AS 1170.2: Structural design actions - Wind actions.
- * AS 1302: Geometrical product specifications Indication of surface texture in technical production documentation.
- * AS 1554(set) Structural steel welding set.
- * AS 2159: Piling - Design & Installation.
- * AS 2870: Residential slab footings - Construction.
- * AS 3600: Concrete structures.
- * AS 3678: Structural steel - Hot rolled plates, floorplates and slabs.
- * AS 4680: Hot dip galvanized (Zinc) Coatings on fabricated ferrous articles.
- * AS/NZS 4671: Steel reinforcing materials.
- * AS/NZS 4600: Cold formed steel structures.
- * AS/NZS 4676: Structural design requirements for utility services poles.



G&S Industries

97 GUTHRIE STREET, OSBORNE PARK W.A. 6017
PH (08) 9446 8044. (08) 9446 8266
FAX (08) 9446 5456

JOB NO.

DATE:

DESIGN:

S.G.

DRAWN:

Z.L.

9.5M FIXED TAPERED OCTAGONAL COLUMN
F9.5DM
610039

CHECKED:

R.G.

APPROVED:

Y

LAST REVISED:

4 SEPT '06

SCALE:

NTS

DRAWING:

ZLRG2217

REVISION:

01

1

2

3

4