

M18 HOLE THROUGH BOTH SIDES OF PIPE
TOP VIEW

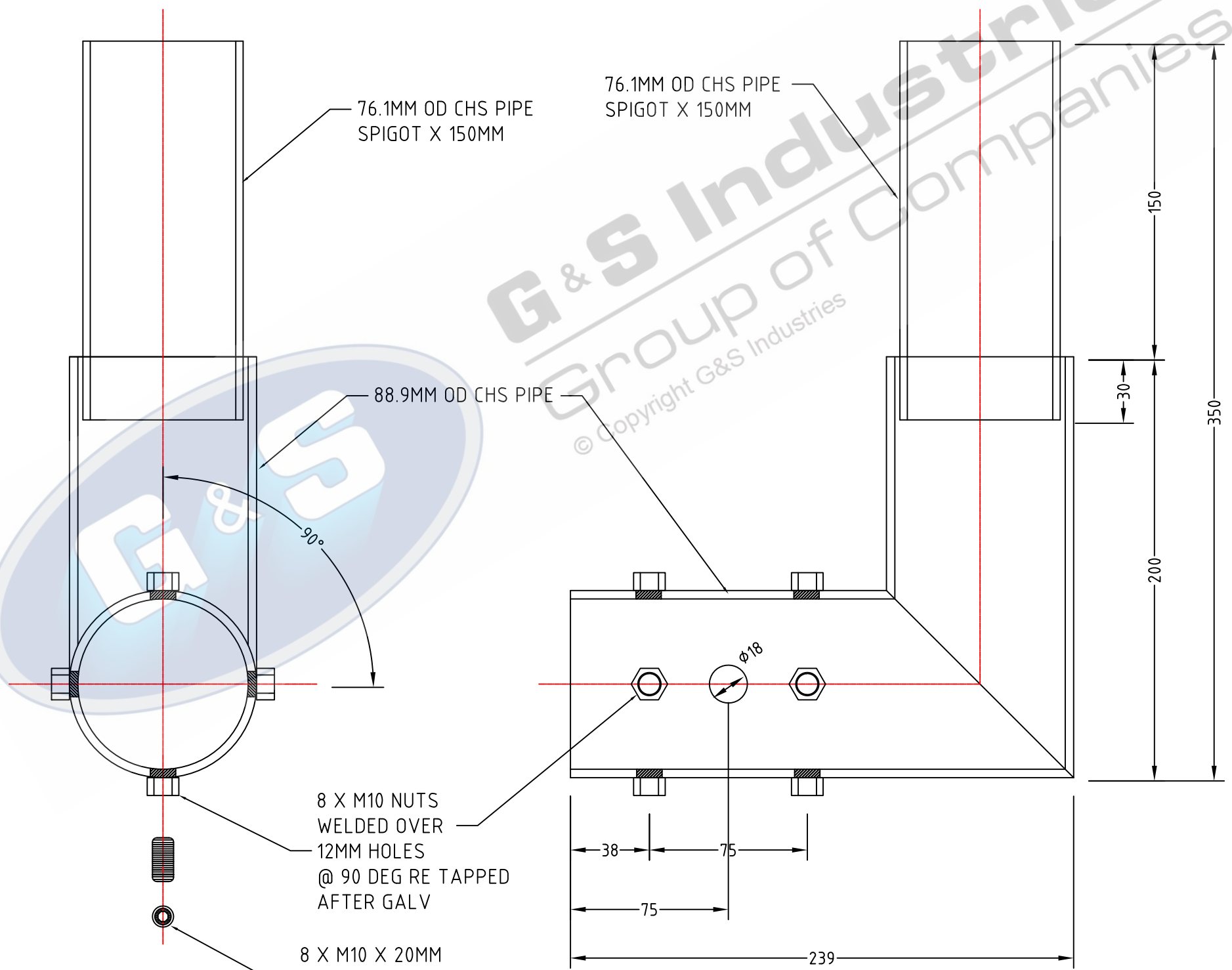

FRONT VIEW

SIDE VIEW

HOT DIPPED GALVANIZED
EST PRODUCT WEIGHT: 4.4G'S

STANDARDS
ALL PRODUCTS TO CONFORM TO THE FOLLOWING AUSTRALIAN STANDARDS
 • AS 1170.2: Structural design actions – Wind actions.
 • AS 1302: Geometrical product specifications Indication of surface texture in technical production documentation.
 • AS 1554(set) Structural steel welding set.
 • AS 2159: Piling – Design & Installation.
 • AS 2870: Residential slab footings – Construction.
 • AS 3600: Concrete structures.
 • AS 3678: Structural steel – Hot rolled plates, floorplates and slabs.
 • AS 4680: Hot dip galvanized (Zinc) Coatings on fabricated ferrous articles.
 • AS/NZS 4671: Steel reinforcing materials.
 • AS/NZS 4600: Cold formed steel structures.
 • AS/NZS 4676: Structural design requirements for utility services poles.



97 GUTHRIE STREET, OSBORNE PARK W.A. 6017
PH (08) 9446 8044, (08) 9446 8266
FAX (08) 9446 5456

JOB NO. xx DATE: 14/08/13

BM03 – 90 DEGREE ARM
TO SUIT BM01 OR BM02 –
BUILDING MOUNT BRACKETS

DESIGN: S.G. DRAWN: R.G.

CHECKED: B.M. APPROVED: S.G.

LAST REVISED: 14/08/13 SCALE: NTS SHEET: A3

DRAWING: ZLRG2545 REVISION: 00 SHEET: 1 OF 1