

1

2

3

4

A

A

B

B

C

C

D

D

E

E

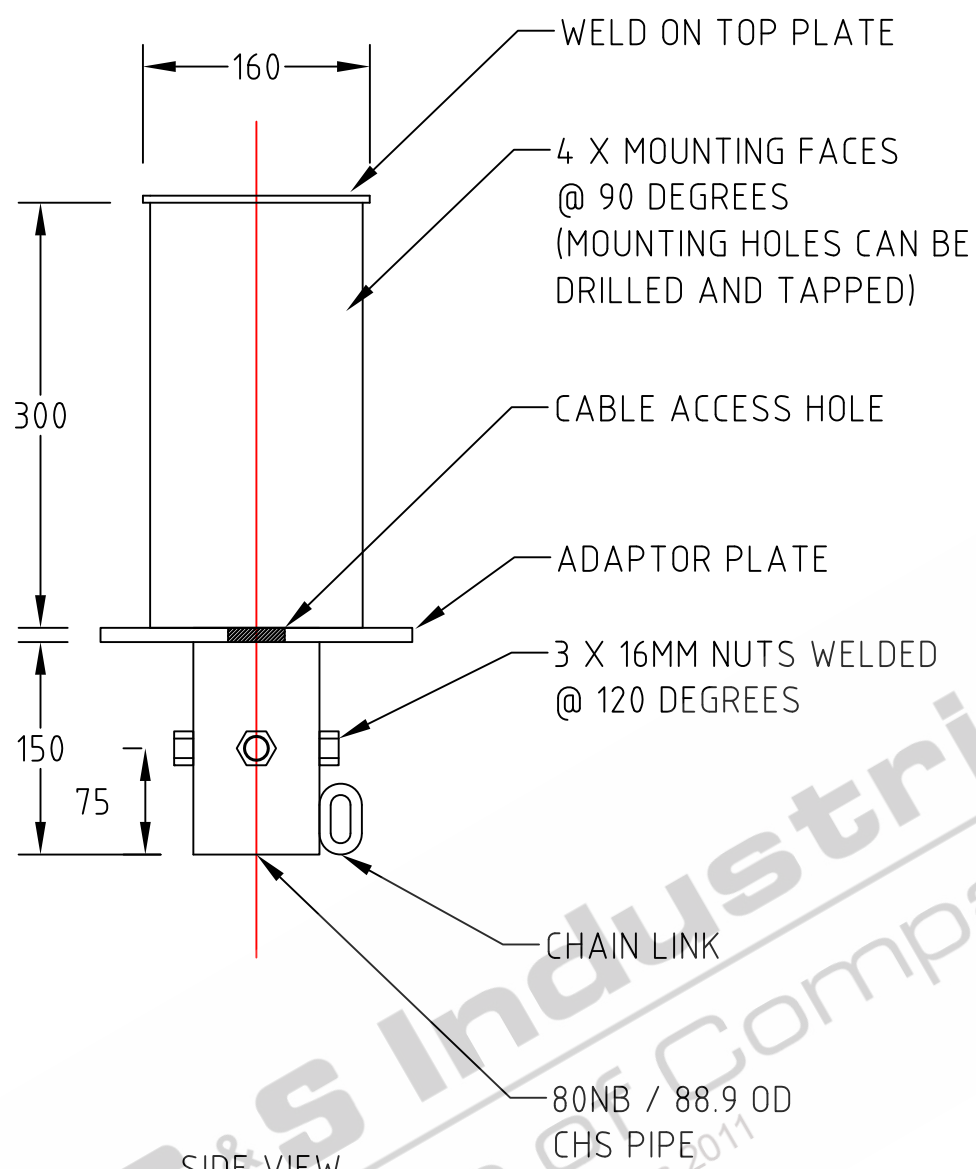

SIDE VIEW

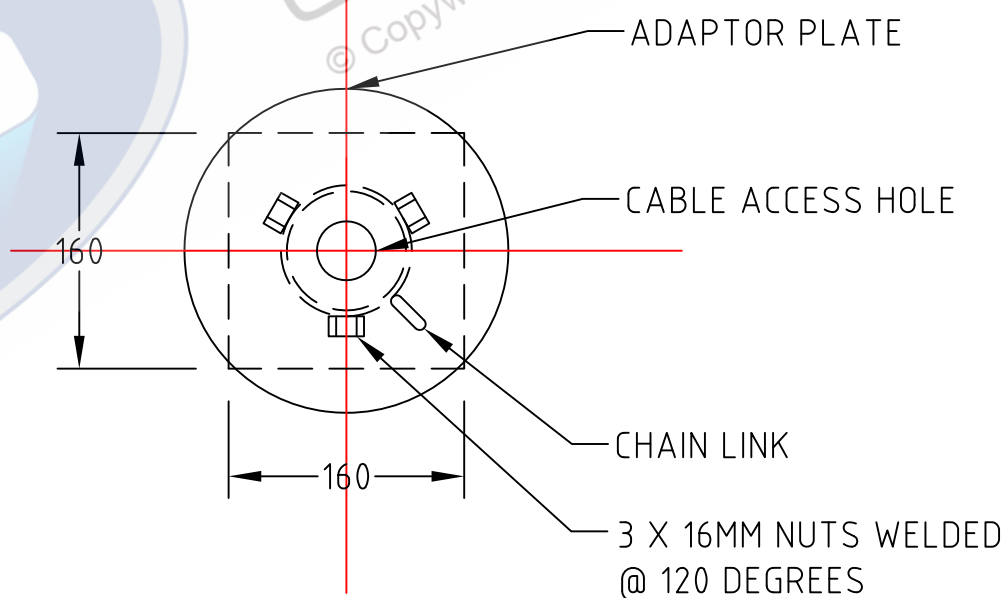

BELOW VIEW

STANDARDS

- ALL PRODUCTS TO CONFORM TO THE FOLLOWING AUSTRALIAN STANDARDS
- * AS 1170.2: Structural design actions – Wind actions.
 - * AS 1302: Geometrical product specifications indication of surface texture in technical production documentation.
 - * AS 1554(set) Structural steel welding set.
 - * AS 2159: Piling – Design & Installation.
 - * AS 2870: Residential slab footings – Construction.
 - * AS 3600: Concrete structures.
 - * AS 3678: Structural steel – Hot rolled plates, floorplates and slabs.
 - * AS 4680: Hot dip galvanized (Zinc) Coatings on fabricated ferrous articles.
 - * AS/NZS 4671: Steel reinforcing materials.
 - * AS/NZS 4600: Cold formed steel structures.
 - * AS/NZS 4676: Structural design requirements for utility services poles.

EST PRODUCT WEIGHT: 7.8KG'S
EST SAIL AREA: 0.048m²



97 GUTHRIE STREET, OSBORNE PARK W.A. 6017
PH (08) 9446 8044. (08) 9446 8266
FAX (08) 9446 5456

JOB NO.

CM011
4 – WAY CAMERA DOME
SPIGOT
710027A

DATE:

31/08/10

DESIGN:

R.M.G

DRAWN:

R.M.G

CHECKED:

S.G

APPROVED:

LAST REVISED:

31/08/10

SCALE:

1:120

SHEET:

A4

DRAWING:

ZLRG2156A

REVISION:

A

SHEET:

1 of 1

1

2

3

4