

1 2 3 4

A

B

C

D

E

A

B

C

D

E

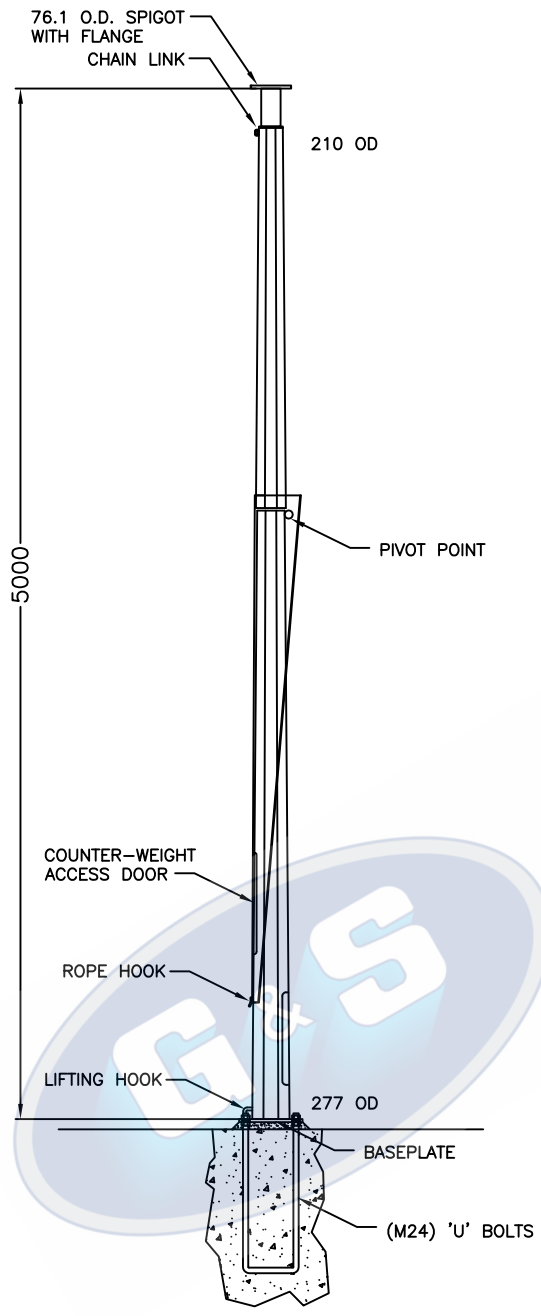

**ELEVATION**

TOTAL WEIGHT OF COLUMN: 163 KG'S

RIGID DESIGN FOR CCTV CAMERA OPERATION WITH MINIMAL DEFLECTION RATING.

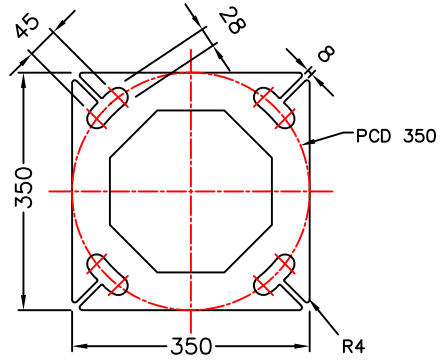

**BASEPLATE THICKNESS: 25mm  
BASEPLATE DETAILS**

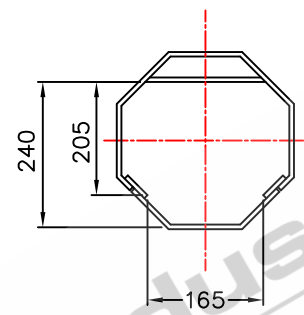

**CONTROL GEAR  
CLEARANCE DETAILS**

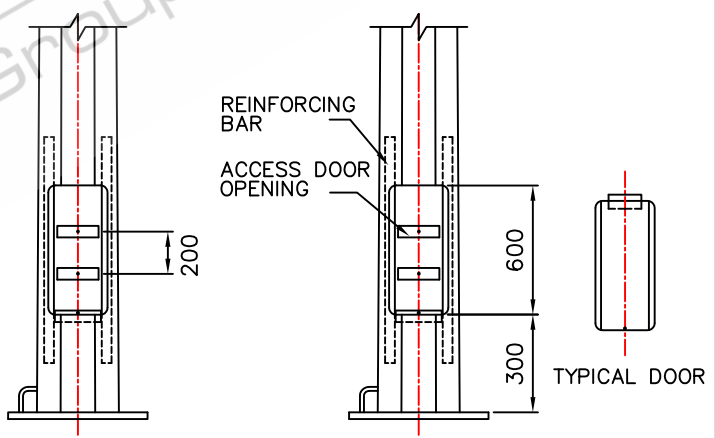

**ELEVATION ON DOOR  
DOOR REMOVED FOR CLARITY**

- STANDARDS**  
 ALL PRODUCTS TO CONFORM TO THE FOLLOWING AUSTRALIAN STANDARDS  
 \* AS 1170.2: Structural design actions - Wind actions.  
 \* AS 1302: Geometrical product specifications indication of surface texture in technical production documentation.  
 \* AS 1554(set) Structural steel welding set.  
 \* AS 2159: Piling - Design & Installation.  
 \* AS 2870: Residential slab footings - Construction.  
 \* AS 3600: Concrete structures.  
 \* AS 3678: Structural steel - Hot rolled plates, floorplates and slabs.  
 \* AS 4680: Hot dip galvanized (Zinc) Coatings on fabricated ferrous articles.  
 \* AS/NZS 4671: Steel reinforcing materials.  
 \* AS/NZS 4600: Cold formed steel structures.  
 \* AS/NZS 4676: Structural design requirements for utility services poles.



97 GUTHRIE STREET, OSBORNE PARK W.A. 6017  
 PH (08) 9446 8044, (08) 9446 8266  
 FAX (08) 9446 5456

JOB NO.	DATE:	DESIGN:	DRAWN:
5M MID-HINGED TAPERED OCTAGONAL COLUMN CCTV5BMHM 710008		S.G.	Z.L.
		CHECKED:	APPROVED:
		R.G.	Y
		LAST REVISED:	SCALE:
		4 SEPT '06	NTS
		DRAWING:	REVISION:
		ZLRG2141	01

1

2

3

4