

1

2

3

4

A

A

B

B

C

C

D

D

E

E

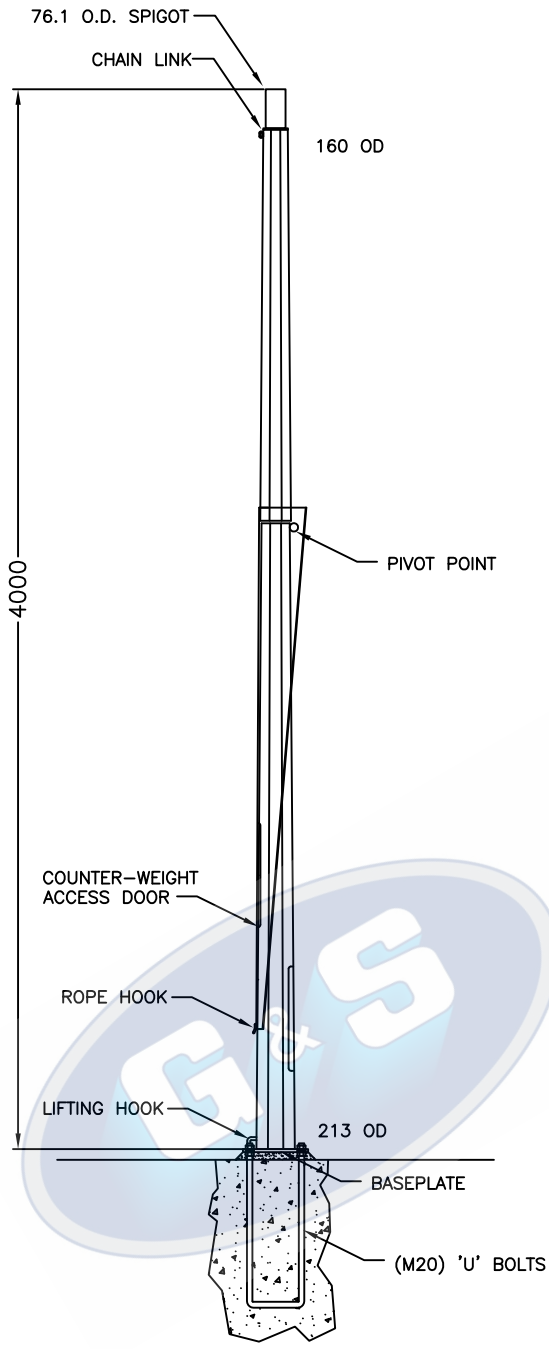

ELEVATION

TOTAL WEIGHT OF COLUMN: 110KG'S

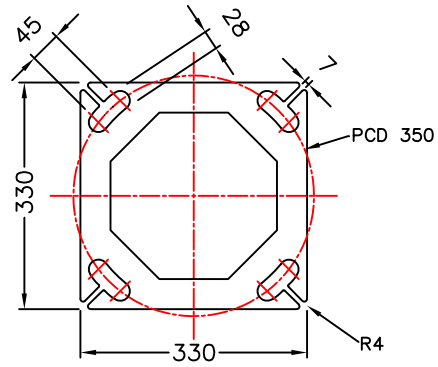

BASEPLATE THICKNESS: 20mm
BASEPLATE DETAILS

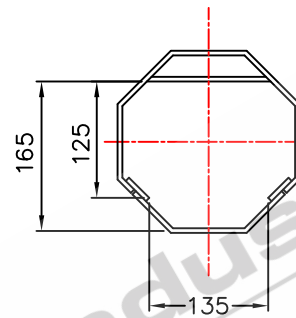

CONTROL GEAR CLEARANCE DETAILS

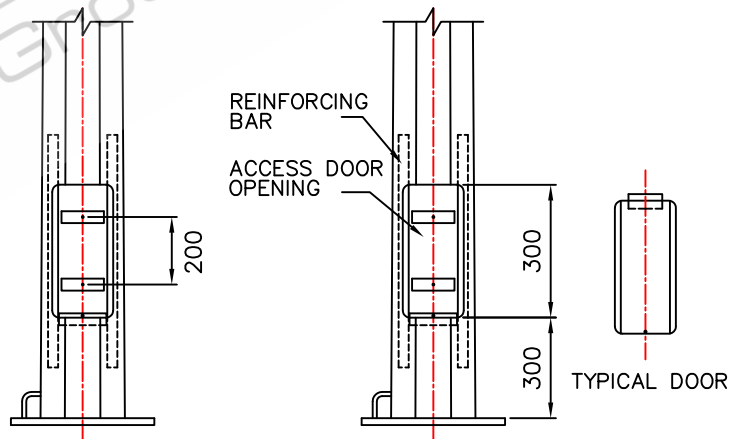

ELEVATION ON DOOR
DOOR REMOVED FOR CLARITY

STANDARDS

- ALL PRODUCTS TO CONFORM TO THE FOLLOWING AUSTRALIAN STANDARDS
- * AS 1170.2: Structural design actions - Wind actions.
 - * AS 1302: Geometrical product specifications indication of surface texture in technical production documentation.
 - * AS 1554(set) Structural steel welding set.
 - * AS 2159: Piling - Design & Installation.
 - * AS 2870: Residential slab footings - Construction.
 - * AS 3600: Concrete structures.
 - * AS 3678: Structural steel - Hot rolled plates, floorplates and slabs.
 - * AS 4680: Hot dip galvanized (Zinc) Coatings on fabricated ferrous articles.
 - * AS/NZS 4671: Steel reinforcing materials.
 - * AS/NZS 4600: Cold formed steel structures.
 - * AS/NZS 4676: Structural design requirements for utility services poles.



97 GUTHRIE STREET, OSBORNE PARK W.A. 6017
PH (08) 9446 8044. (08) 9446 8266
FAX (08) 9446 5456

JOB NO.	DATE:	DESIGN: S.G.	DRAWN: Z.L.
4M MID-HINGED TAPERED OCTAGONAL COLUMN MH4BH 630002		CHECKED: R.G.	APPROVED: Y
		LAST REVISED: 4 SEPT '06	SCALE: NTS
		DRAWING: ZLRG2060	REVISION: 01

1

2

3

4