

1

2

3

4

A

A

B

B

C

C

D

D

E

E

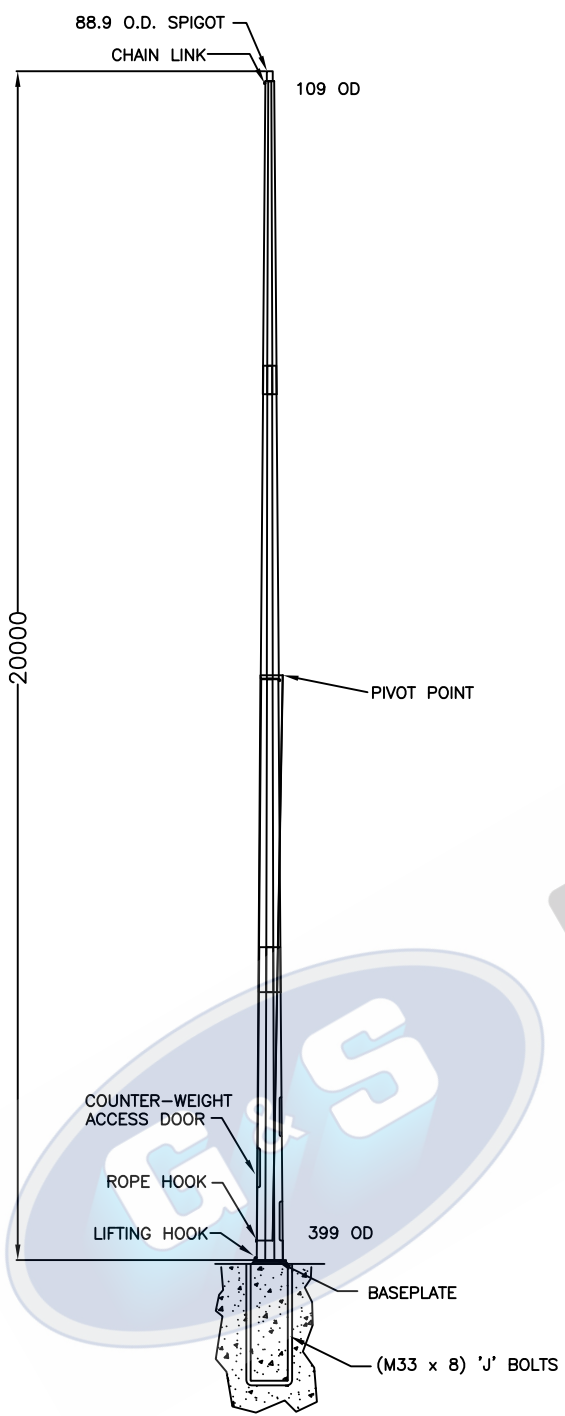

ELEVATION

TOTAL WEIGHT OF COLUMN: 1077KG'S

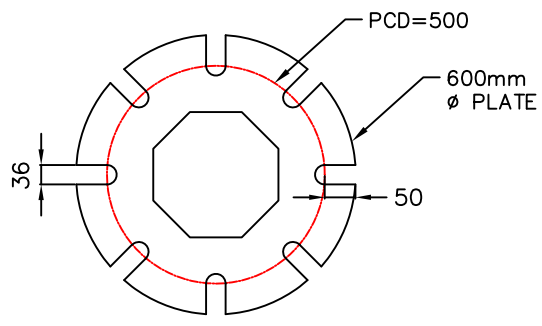

BASEPLATE THICKNESS: 32mm
BASEPLATE DETAILS

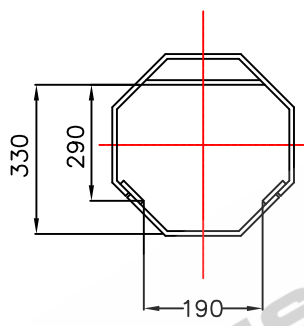

CONTROL GEAR CLEARANCE DETAILS

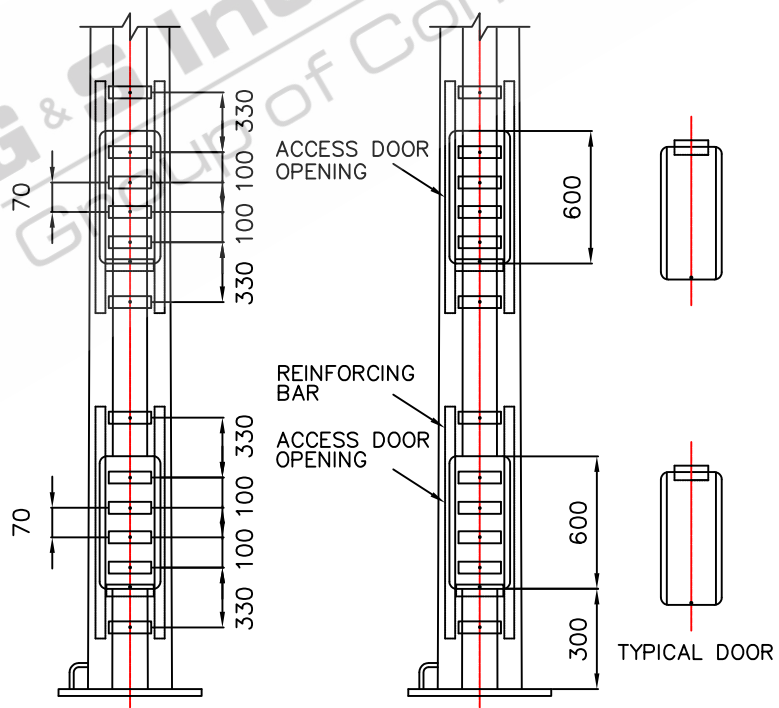

ELEVATION ON DOORS
DOORS REMOVED FOR CLARITY

- STANDARDS**
ALL PRODUCTS TO CONFORM TO THE FOLLOWING AUSTRALIAN STANDARDS
- * AS 1170.2: Structural design actions - Wind actions.
 - * AS 1302: Geometrical product specifications indication of surface texture in technical production documentation.
 - * AS 1554(set): Structural steel welding set.
 - * AS 2159: Piling - Design & Installation.
 - * AS 2870: Residential slab footings - Construction.
 - * AS 3600: Concrete structures.
 - * AS 3678: Structural steel - Hot rolled plates, floorplates and slabs.
 - * AS 4680: Hot dip galvanized (Zinc) Coatings on fabricated ferrous articles.
 - * AS/NZS 4671: Steel reinforcing materials.
 - * AS/NZS 4600: Cold formed steel structures.
 - * AS/NZS 4676: Structural design requirements for utility services poles.



G&S Industries

97 GUTHRIE STREET, OSBORNE PARK W.A. 6017
PH (08) 9446 8044. (08) 9446 8266
FAX (08) 9446 5456

JOB NO.	DATE:	DESIGN:	DRAWN:
20M MID-HINGED TAPERED OCTAGONAL COLUMN MH20BH 630009A		S.G.	Z.L.
		CHECKED:	APPROVED:
		R.G.	Y
		LAST REVISED:	SCALE:
		4 SEPT '06	NTS
		DRAWING:	REVISION:
		ZLRG2073	01

1

2

3

4