

**ELEVATION**

TOTAL WEIGHT OF COLUMN: 696.00KG'S

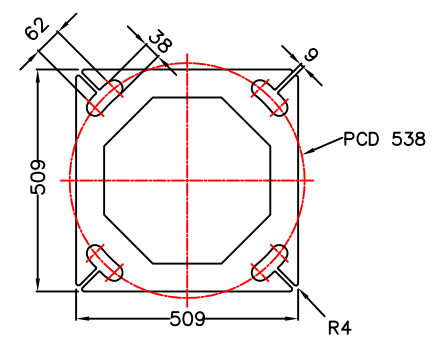

BASEPLATE THICKNESS: 32mm  
**BASEPLATE DETAILS**

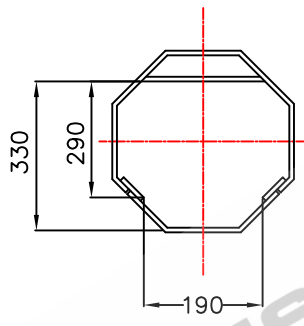

**CONTROL GEAR CLEARANCE DETAILS**

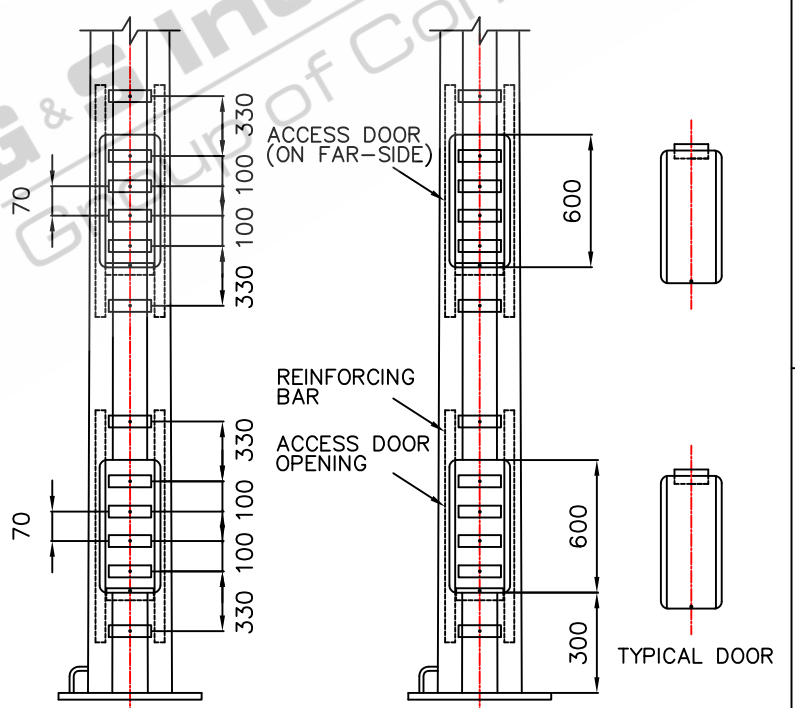

**ELEVATION ON DOORS**  
DOORS REMOVED FOR CLARITY

- STANDARDS  
ALL PRODUCTS TO CONFORM TO THE FOLLOWING AUSTRALIAN STANDARDS
- \* AS 1170.2: Structural design actions – Wind actions.
  - \* AS 1302: Geometrical product specifications indication of surface texture in technical production documentation.
  - \* AS 1554(set): Structural steel welding set.
  - \* AS 2159: Piling – Design & Installation.
  - \* AS 2870: Residential slab footings – Construction.
  - \* AS 3600: Concrete structures.
  - \* AS 3678: Structural steel – Hot rolled plates, floorplates and slabs.
  - \* AS 4680: Hot dip galvanized (Zinc) Coatings on fabricated ferrous articles.
  - \* AS/NZS 4671: Steel reinforcing materials.
  - \* AS/NZS 4600: Cold formed steel structures.
  - \* AS/NZS 4676: Structural design requirements for utility services poles.



97 GUTHRIE STREET, OSBORNE PARK W.A. 6017  
PH (08) 9446 8044. (08) 9446 8266  
FAX (08) 9446 5456

JOB NO.	DATE:	DESIGN:	DRAWN:
22M FIXED TAPERED OCTAGONAL COLUMN		S.G.	Z.L.
F22BM		CHECKED:	APPROVED:
610026		R.G.	Y
		LAST REVISED:	SCALE:
		4 SEPT '06	NTS
		DRAWING:	REVISION:
		ZLRG2056	01