

1 2 3 4

A

A

B

B

C

C

D

D

E

E

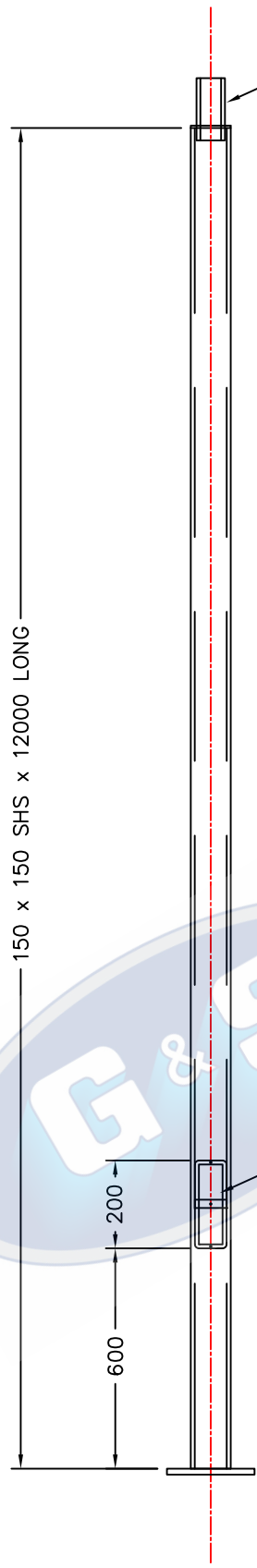

Spigot to suit headframe or light fitting.

150 x 150 SHS x 12000 LONG

200
600

Flush door 200x50 clear opening with 1x fuse mounting strap C/W 6mm tapped hole.

COLUMN WEIGHT: 311 KG'S

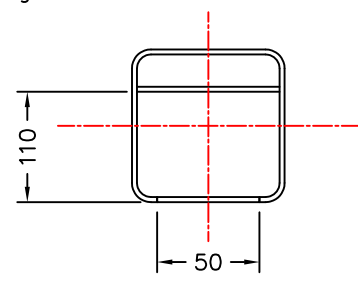

DOOR CLEARANCES

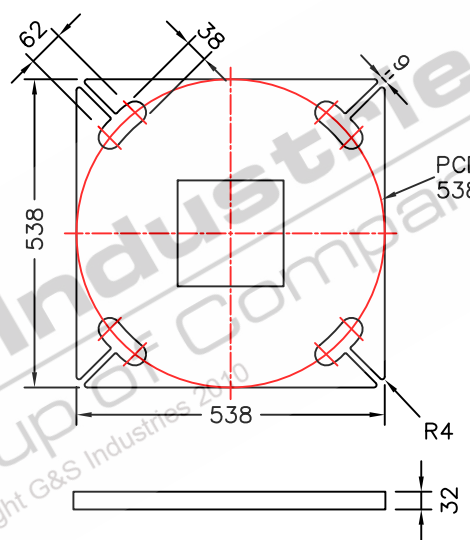

E3B
BASEPLATE DETAILS

- STANDARDS**
 ALL PRODUCTS TO CONFORM TO THE FOLLOWING AUSTRALIAN STANDARDS
- * AS 1170.2: Structural design actions – Wind actions.
 - * AS 1302: Geometrical product specifications indication of surface texture in technical production documentation.
 - * AS 1554(set) Structural steel welding set.
 - * AS 2159: Piling – Design & Installation.
 - * AS 2870: Residential slab footings – Construction.
 - * AS 3600: Concrete structures.
 - * AS 3678: Structural steel – Hot rolled plates, floorplates and slabs.
 - * AS 4680: Hot dip galvanized (Zinc) Coatings on fabricated ferrous articles.
 - * AS/NZS 4671: Steel reinforcing materials.
 - * AS/NZS 4600: Cold formed steel structures.
 - * AS/NZS 4676: Structural design requirements for utility services poles.



97 GUTHRIE STREET OSBORNE PARK W.A. 6017
 PH. (08) 9446 8044, (08) 9446 8266
 FAX (08) 9446 5456

JOB No	DATE:	DESIGN: SG	DRAWN: ZL
SQUARE SHS COLUMN S150B12		CHECKED: RG	APPROVED Y
12m POST TOP COLUMN		LAST REVISED: 11 DEC '10	SCALE NTS
BASEPLATE MOUNTED		DRAWING ZLRG2127	REVISION 02
660017			

1 2 3 4